

## **Chapter 6**

# **Small signal analysis and control design of LLC converter**

### **6.1 Introduction**

In previous chapters, the characteristic, design and advantages of LLC resonant converter were discussed. As demonstrated in chapter 3, LLC resonant converter has very low switching loss. Because of low voltage stress on secondary rectifier, low voltage rated diodes could be used, conduction loss is also much reduced compared with PWM converter. With DC analysis and understanding of the operation of LLC resonant converter, power stage parameters could be designed to meet given specifications.

To use LLC resonant converter as front end DC/DC converter, still another important issue need to be investigated: small signal characteristic. Small signal characteristic is essential for the feedback loop design. For front end DC/DC converter, feedback control is needed to provide a tight regulation of output voltage with load and input variation, which happens all the time for front end DC/DC converter. In Figure 6.1, the whole converter with control circuit is shown. For LLC resonant converter, variable frequency control is used. To achieve variable frequency control, instead of PWM comparator in PWM controller, a Voltage Controlled Oscillator (VCO) is used to convert control

voltage  $V_c$  to the variable frequency square wave, which is used to drive the switches. To design the compensator, we have to know the small signal characteristic of the converter. In this part, the small signal characteristic of LLC resonant converter with VCO will be investigated. Base on the small signal characteristic of LLC resonant converter, the compensator design will be investigated later.

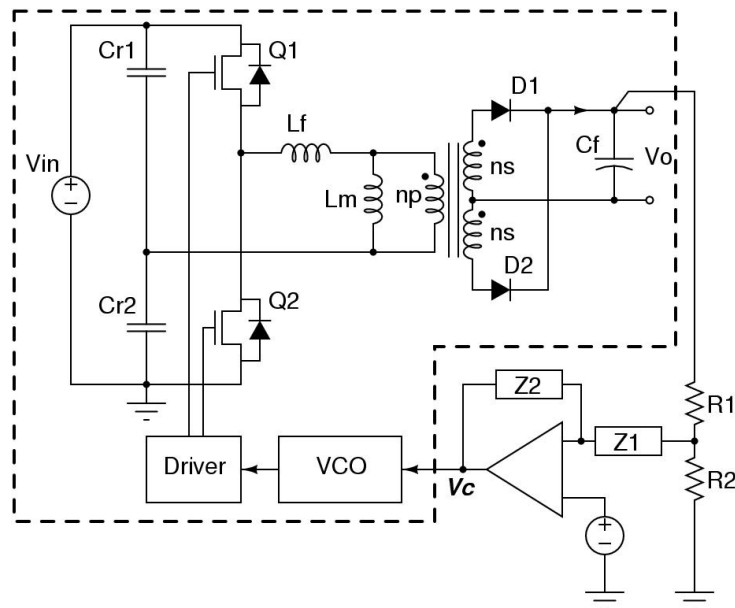

Figure 6.1 LLC resonant converter with feedback control

For PWM converter, state space average method has been widely used. State space average method provides simple and accurate solution for up to half switching frequency. It has been verified and the theoretical system has been well established. With the small signal model derived from state space average method, small signal characteristic of PWM converter can be studied and control circuit can be designed accordingly.

Unfortunately, state space averaging method cannot be applied for frequency controlled resonant converter. This is because of the totally different ways of energy processing methods for these two kinds of power converter. For PWM converter, the natural frequency of the linear network (output filter) is much lower than the switching frequency. The modulation of the converter is achieved through the low frequency content in the control signal. With this character, the average method can provide approximate linear solution of the nonlinear state equations. The derived model has a continuous form and is accurate up to half of switching frequency. However, for resonant converter, the switching frequency is close to the natural frequency of the linear network (resonant tank). The states contain mainly switching frequency harmonics instead of low frequency content in PWM converter. The modulation of the resonant converter is achieved by the interaction between switching frequency and resonant frequency. Since average method will eliminate the information of switching frequency, it cannot predict the dynamic performance of resonant converter [D-6][D-7].

In the past, several methods were tried to solve this problem. Among these methods, some made too many simplifications that the results cannot match with test results. Some of them are very complex and difficult to use [D-8][D-9].

In this dissertation, two methods were used. One is Extended Describing Function method developed by Dr. Eric X. Yang. This method is a simplified version of describing function method. A software package in Matlab is also

developed to realize this method. With the software package, small signal characteristic of a converter could be derived with short simulation time.

Another method used in this dissertation is a simulation-based method. This method uses simulation tools to emulate the function of impedance analyzer to get the small signal response of the converter. The method is based on time domain switching model simulation, which is a necessary for every converter design. So no extra modeling effort is needed for this method. It could be used to any periodical operating converter. It is a very effective method to deal with complex topology, which is difficult to deal with conventional method. Also, the impact of parasitic could also be easily included into this method.

This chapter is organized in following way. First, two methods: extended describing function method and simulation-based method, will be introduced. With these two methods, small signal characteristic of LLC resonant converter will be studied. Load impact, and resonant tank value impact will be studied with these tools. Finally, the results from these two methods will be compared with test results.

With the information of small signal characteristic of LLC resonant converter, the design of the compensator will be discussed.

## 6.2 Extended Describing Function analysis

Dr. Eric X. Yang published extended describing function method in [D-12]. This method is a simplified modeling method based on the describing function method published by J. O. Groves [D-9]. With this method, the small signal model of a periodical operating converter could be derived with any order of harmonics of switching frequency taken into consideration. This method could be used for PWM converter. With only DC components of state variables taken into consideration, it is same as state space averaging method. For resonant converter, since switching frequency and its harmonics also play important roles in the power transfer process. State space averaging method could not be applied. With extended describing function, high order harmonics could be included so that an accurate model could be derived. The detail of extended describing function method and introduction of the software package could be found in [D-12]. The process of building the model for extended describing function is discussed in Appendix D. The model file of LLC resonant converter needed to perform the analysis are attached in Appendix D too.

In next part, the small signal characteristic of LLC resonant converter will be discussed using extended describing function method. The circuit parameters used for this analysis is shown in Figure 6.2.

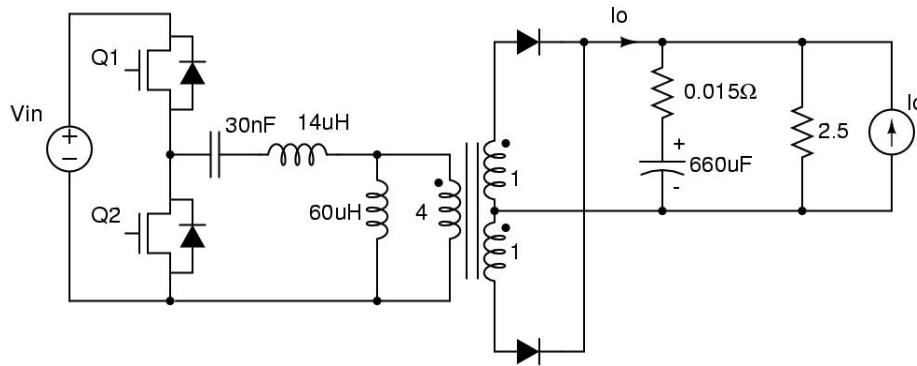

Figure 6.2 Circuit parameters for extended describing function analysis

For extended describing function method, the order of harmonics needed for accurate model is one thing needs to be determined before doing the analysis. For traditional resonant topologies like SRC and PRC, only the fundamental harmonic of switching frequency will be sufficient to provide an accurate small signal model [D-11][D-12]. For LLC resonant converter, though, it is a multi resonant converter. The fundamental component of switching frequency might not be enough.

In Figure 6.3, the control to output transfer function is shown for region 1 (switching frequency higher than series resonant frequency). As seen from the graph, in region 1, fundamental component seems to be enough. With higher order of harmonics took into consideration, the model will not be improved significantly. This is understandable since in region 1, LLC converter operates very similar to SRC.

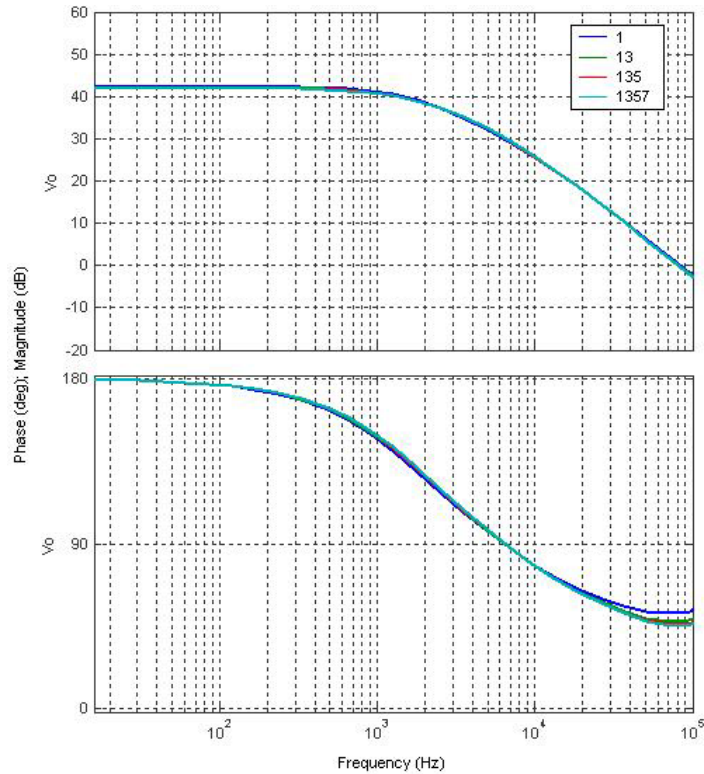

Figure 6.3 Impact of harmonic order on the accuracy of EDF method in region 1

In Figure 6.4, same analysis was done in region 2 (switching frequency lower than series resonant frequency). In region 2, fundamental component is not enough. With more harmonics considered, the model will be different from only consider the fundamental component. But after the 5<sup>th</sup> harmonic, include more harmonics doesn't make any significant difference anymore. In the later simulation, we will use 1<sup>st</sup>, 3<sup>rd</sup> and 5<sup>th</sup> harmonic for analysis. This result is also reasonable because in region 2, LLC resonant converter is working as a multi resonant converter. During each switching cycle, the resonant frequency changes as topology modes progress.

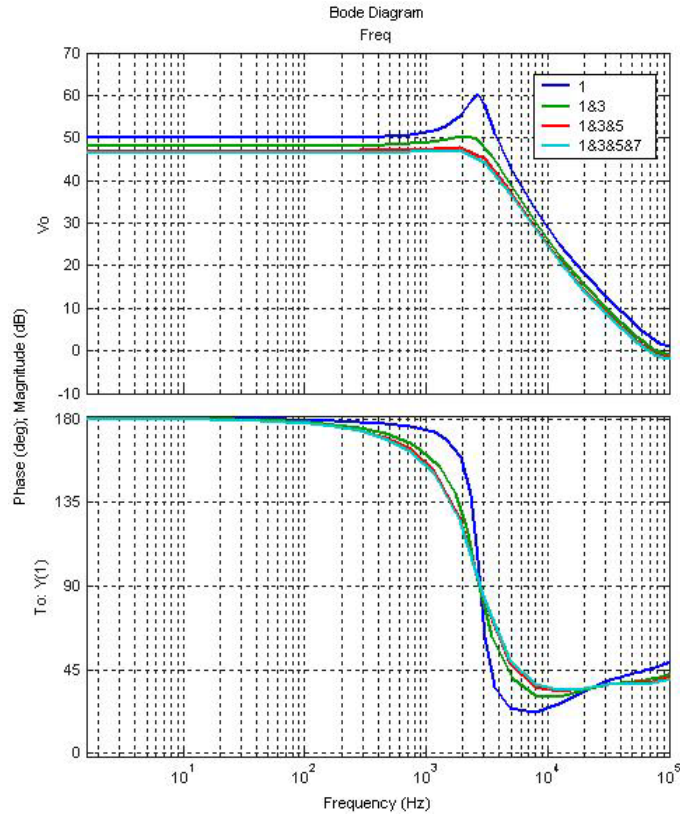

Figure 6.4 Impact of harmonic order on the accuracy of EDF method in region 2

With up to 5<sup>th</sup> harmonic take into consideration; the small signal characteristic of LLC resonant converter is derived with extended describing function method. With this requirement, the simulation time is extended.

Another problem with extended describing function method is that to build the model, every operating modes of the circuit need to be identified. For LLC resonant converter, it has many different operating modes as shown in Appendix B. It would be very difficult to build the model file. Next, time domain simulation-based method will be discussed, which could solve these problems.



### 6.3 Time domain simulation method

This method uses brute force simulation to derive the small signal characteristic of LLC resonant converter. It emulates the function of a network analyzer. To perform this analysis, only the switching model of the converter is needed, there is no other model needed, which makes this method very attractive.

The procedure of this method is shown in Figure 6.5.

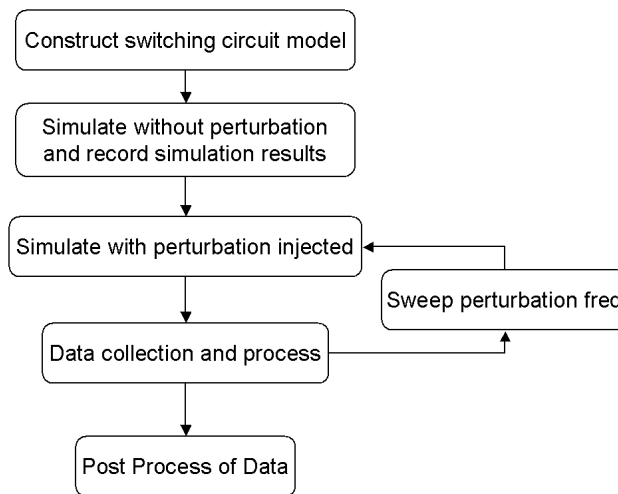

Figure 6.5 Procedure for simulation method to analyze small signal characteristic

First step of this method is to simulate the converter at given operating point (Load condition, switching frequency and input voltage) without perturbation as shown in Figure 6.6. After simulate to steady state, record all the information needed as the base information.

Second step is to simulate the converter with perturbation added to where interested. For example, to investigate the control to output characteristic, a perturbation will be added to the control voltage as shown in Figure 6.7. This

perturbation will be a small amplitude sinusoidal signal with known phase information. The amplitude is small so that the converter operation modes will not change with perturbation added. With perturbation injected, make another time domain simulation to steady state and record all the information interested.

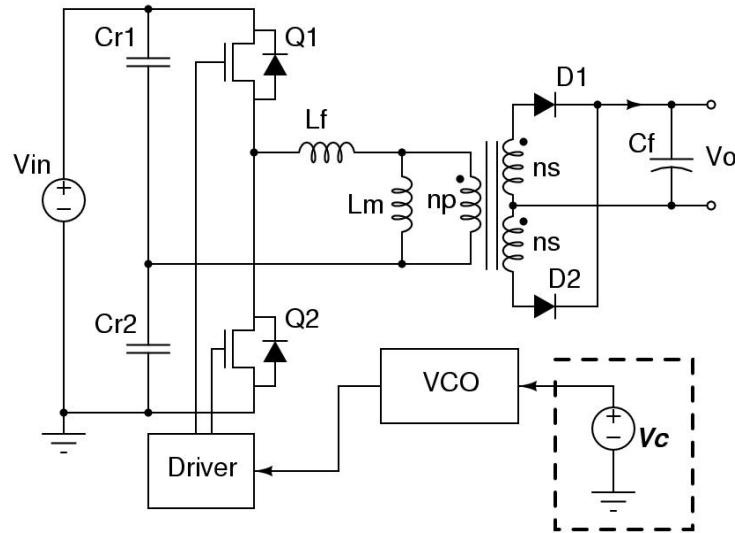

Figure 6.6 Circuit setup for first step simulation

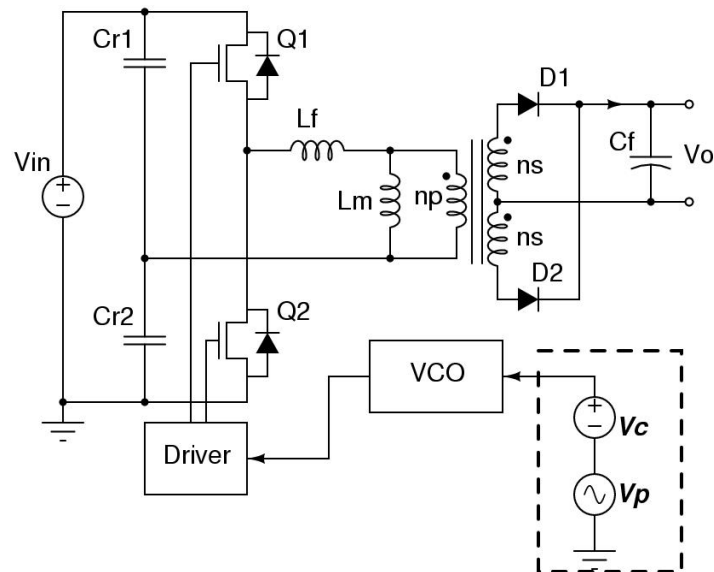

Figure 6.7 Circuit setup for second step simulation

Next, the results of previous two simulations will be compared. The impact of the injected perturbation on output variable could be derived. This will give us the small signal characteristic of the converter at one perturbation frequency. Repeat above steps for the frequency range interested, a complete small signal characteristic at given operating condition could be extracted. If other operating point is interested, change the switching circuit model so that the converter is operated at new operating point.

As can be seen, this method asks for extensive simulation power. Fortunately, with advanced software and computer, this is not so time consuming a method. First, with Simplis® software, above process could be automated. The software could do the sweeping of frequency and operating condition as set. It also performs the extraction of small signal characteristic after each simulation. With this software, one bode plot of the converter at given operating condition could be simulated in two hours.

With simulation method, a SRC was analyzed. The results were shown in Appendix C.

### **6.3.1 Small signal characteristic of LLC resonant converter**

With extended describing function method, the characteristic in region 1 is shown in Figure 6.8. It is a three poles and one zero system.

As seen from the graph, in region 1, there are one beat frequency double pole, one low frequency pole and one ESR zero. As switching frequency moves close to resonant frequency, the beat frequency double pole will move to lower frequency. When the switching frequency is very close to resonant frequency, the beat frequency double pole will eventually split and becomes two real poles. One moves to higher frequency and one move to lower frequency as switching frequency continuous move close to resonant frequency. Finally, the pole moves to low frequency will combine with the low frequency pole caused by the output filter and form a double pole. This characteristic is same as could be observed in SRC converter. In this analysis, the ESR of output capacitor is considered. This ESR will introduce an ESR zero at fixed frequency.

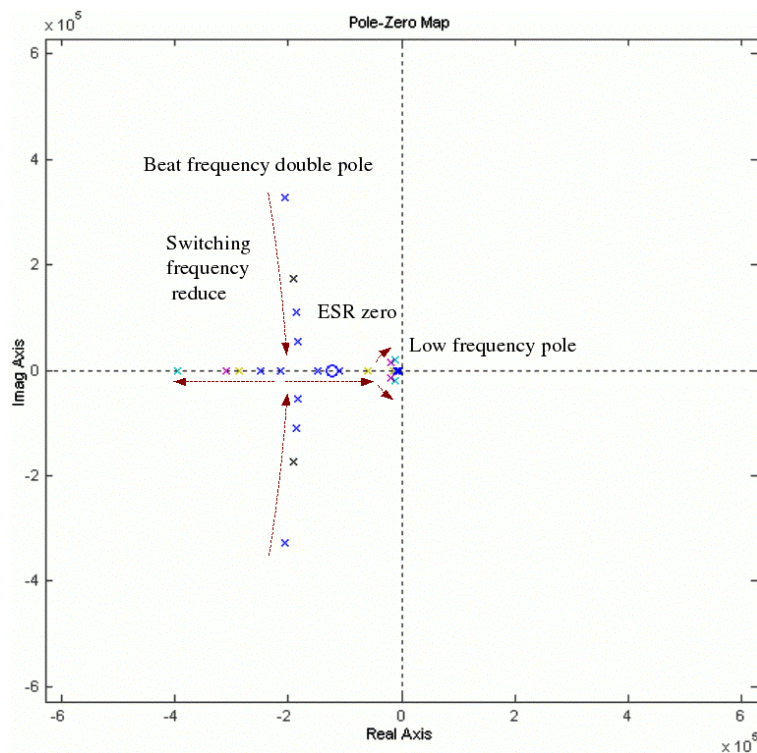

Figure 6.8 System poles and zeros of LLC in region 1 with different switching frequency

Audio susceptibility, input conductance and output impedance in region 1 are also shown in Figure 6.9, Figure 6.10, and Figure 6.11.

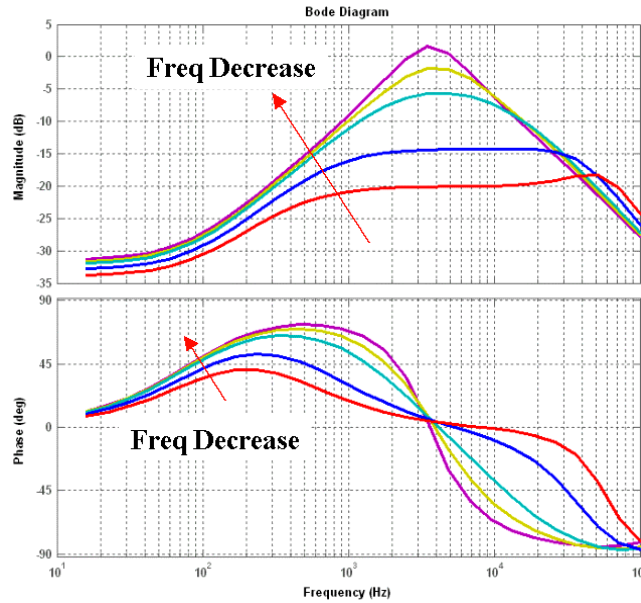

Figure 6.9 Input conductance of LLC converter in region 1

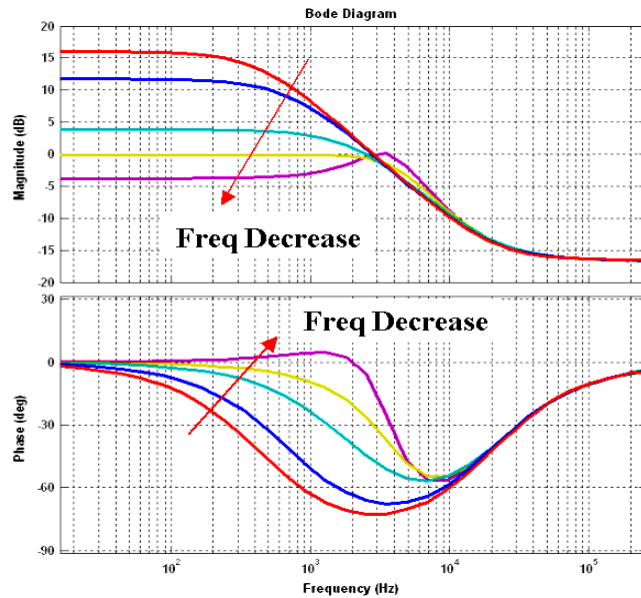

Figure 6.10 Output impedance of LLC resonant converter in region 1

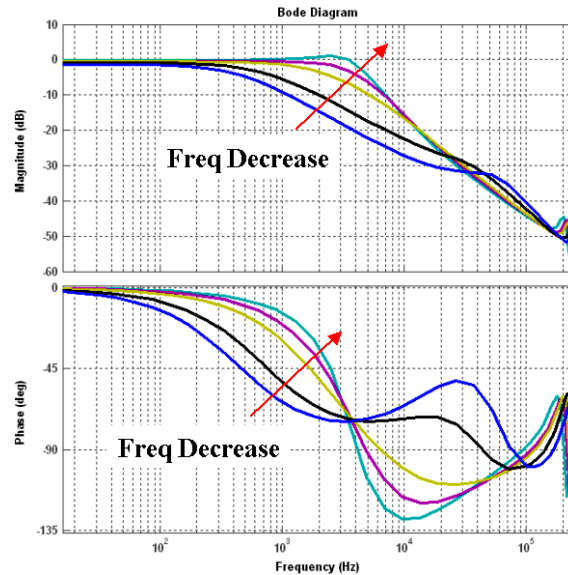

Figure 6.11 Audio susceptibility of LLC converter in region 1

The characteristic in region 2 is shown in Figure 6.12. In this region, the system has some very different characteristic. A Right Half Plane Zero is observable in this region. This RHZ moves with switching frequency. Fortunately, this RHZ doesn't shift to very low frequency region even when switching frequency is very low. This is good since it is not easy to deal with the RHZ.

In left half plane, there are three poles and one zero. They are pretty stable compared with poles and zero in region 1. In region 1, when switching frequency moves close to resonant frequency, one pole moves to higher frequency. When the converter runs into region 2, as switching frequency further reduces, this pole will move back to lower frequency, but not so much. In this region, the switching frequency has less impact on the double pole at low frequency and no impact on the ESR zero.

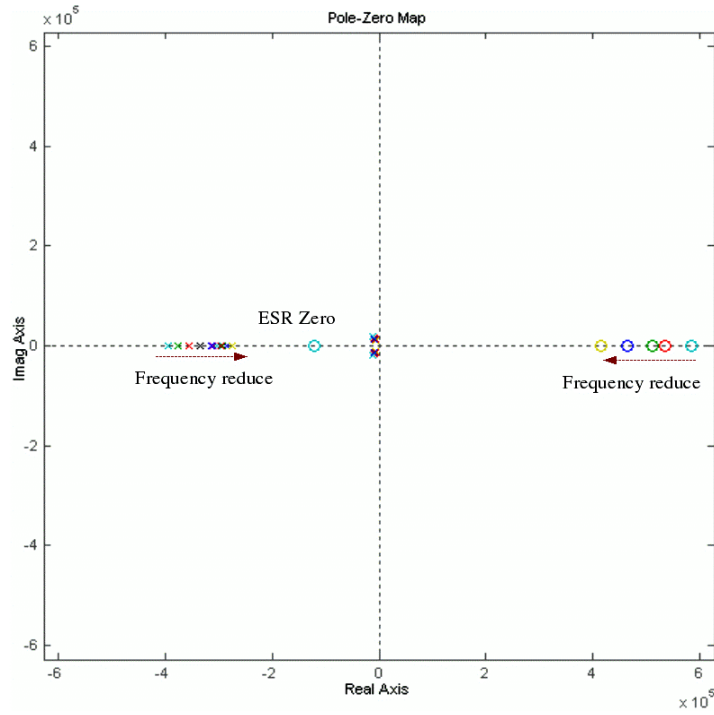

Figure 6.12 System poles and zeros of LLC converter in region 2

Audio susceptibility, input conductance and output impedance in region 2 are also shown in Figure 6.13, Figure 6.14, and Figure 6.15.

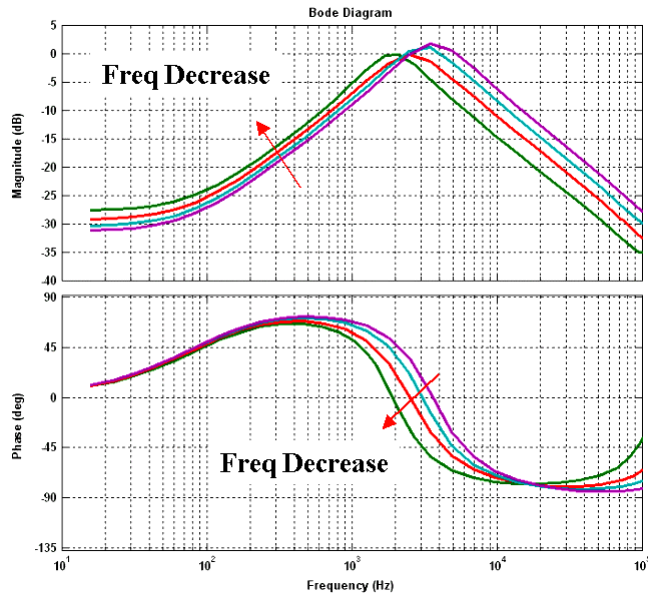

Figure 6.13 Input conductance of LLC resonant converter in region 2

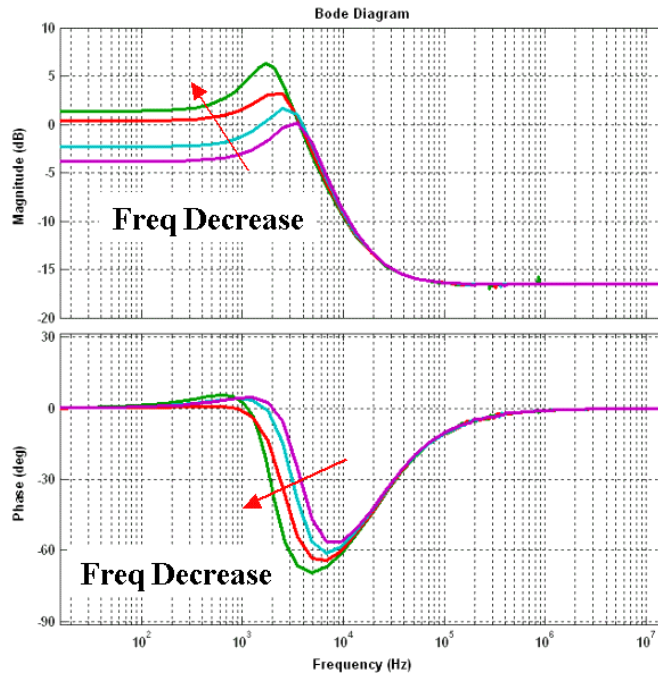

Figure 6.14 Output impedance of LLC resonant converter in region 2

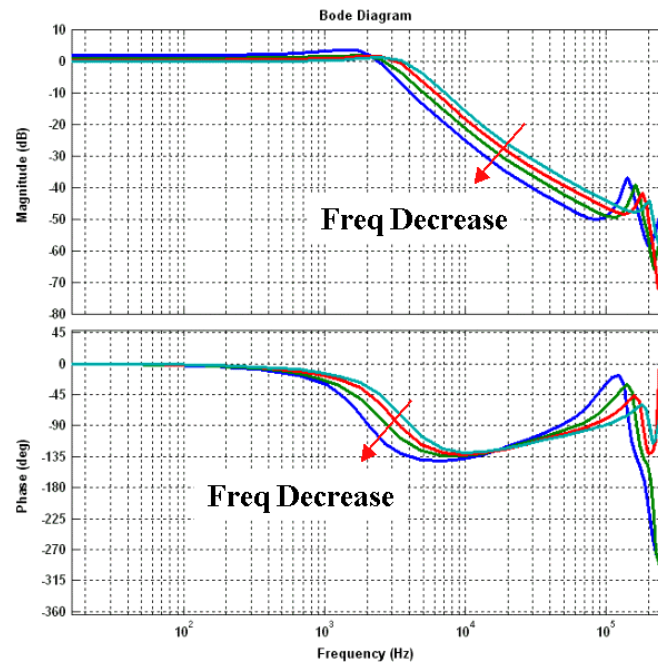

Figure 6.15 Audio susceptibility of LLC resonant converter in region 2



From above analysis results, the small signal model of LLC resonant converter could be extracted. In region 1, this converter is very similar to the series resonant converter. In region 2, though, it is very different. One RHZ could be observed in region 2. The poles and zero in left half plane are very stable with the changing of switching frequency, which is very different from normal resonant converter.

The problem of this method is that to get accurate small signal model of the converter, a good model file is needed. This is a very time consuming process especially when the converter could run into many different operating modes. Another problem is that the accuracy is depends on the order of harmonics took into consideration. With higher order of harmonics, the simulation time and convergence problem will be difficult to deal with. Due to the difficulties to build the model file, it is not easy to take the parasitic components into consideration. In next part, the time domain simulation method will be discussed.

Next, simulation based method will be used. The simulation is performed on LLC resonant converter as shown in Figure 6.16. The resonant frequency of  $C_r$  and  $L_r$  is designed at 250kHz. Here full load condition is used to analyze the small signal characteristic. Later load impact will be investigated.

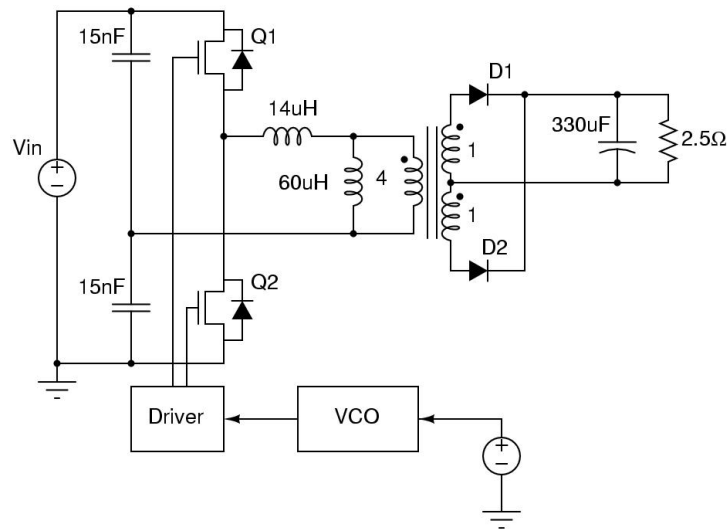

Figure 6.16 LLC converter setup for small signal analysis

In Figure 6.18, the small signal characteristic of LLC resonant converter is shown. The simulation is performed for a switching frequency range from 100kHz to 400kHz to cover all three operating regions. In the small signal characteristic of LLC resonant converter, three distinctive regions exist correspond to the three operating regions shown in the DC characteristic. Next the characteristic of these three regions will be discussed in detail.

For region 1, the converter operates similar as a series resonant converter. The small signal characteristic is also very similar to SRC. Low frequency pole and beat frequency double pole could be observed in this region.

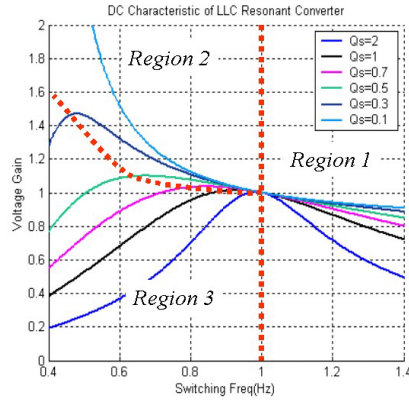

Figure 6.17 Operating region of LLC resonant converter

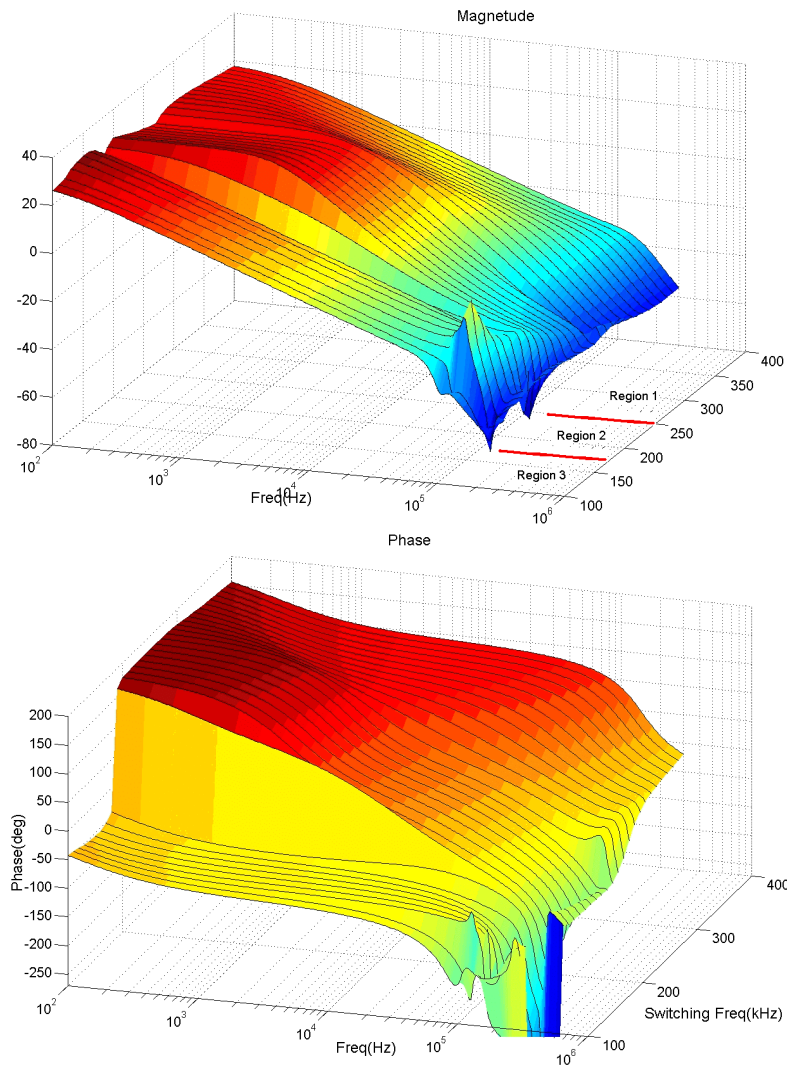

Figure 6.18 Bode plot of control to output transfer function for LLC resonant converter

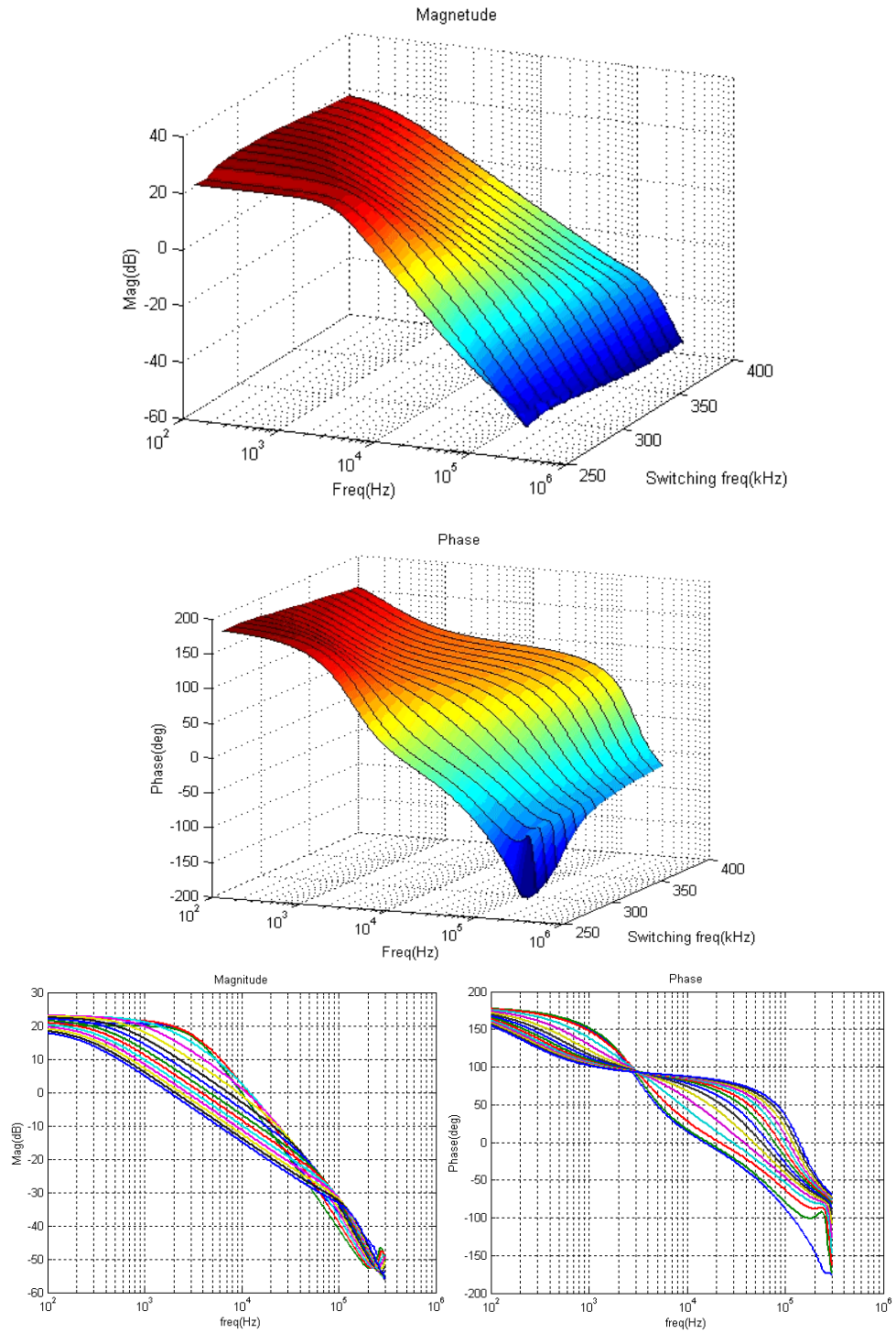

Figure 6.19 Bode plot of control to output transfer function of LLC resonant converter in region 1

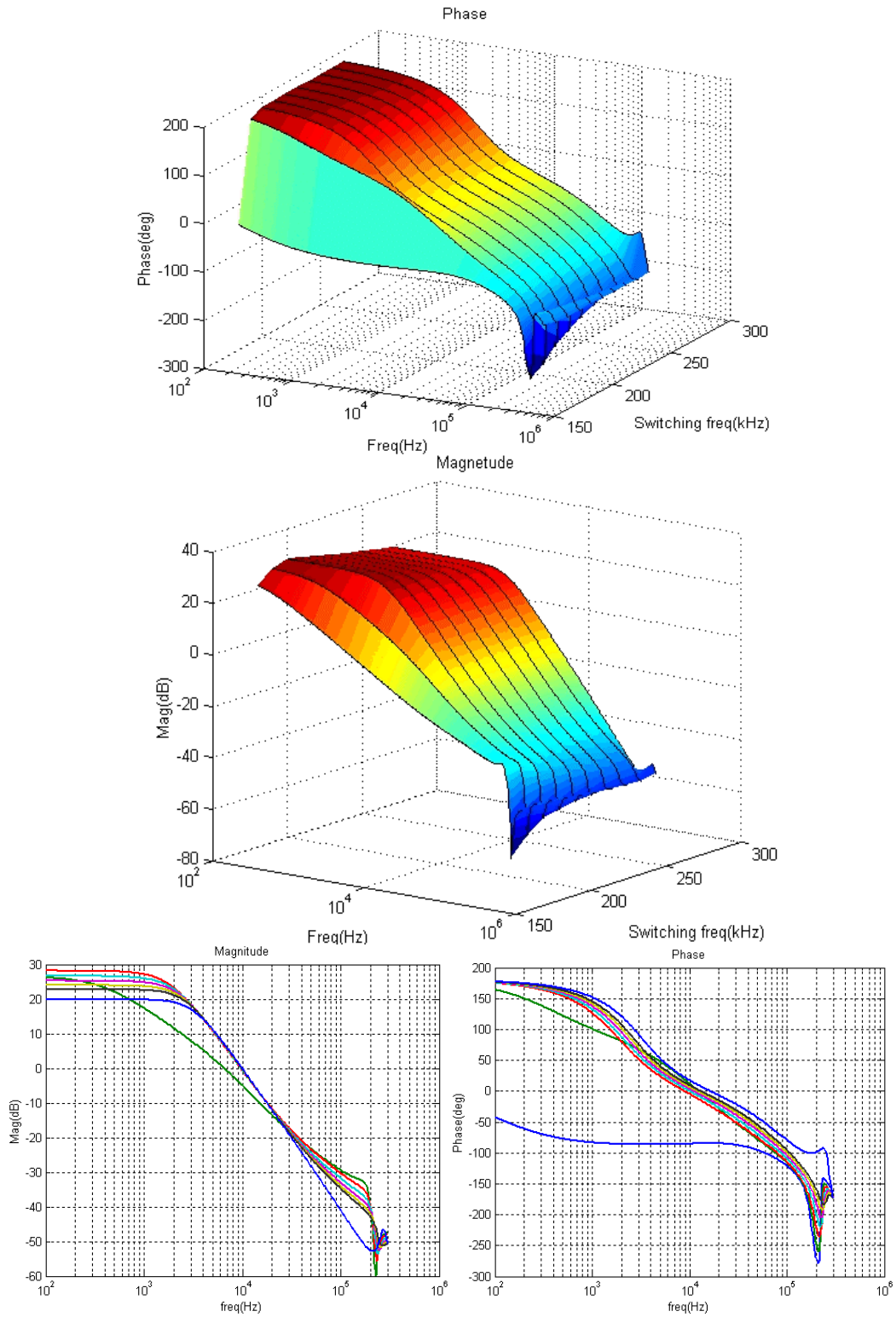

Figure 6.20 Bode plot of control to output transfer function of LLC resonant converter in region 2

The characteristic in region 2 is shown in Figure 6.20. Region 2 is a very interesting region. In this region, the DC characteristic is like a PRC. But for the small signal characteristic of LLC resonant converter is very stable in this region. As seen in the graph, there is no beat frequency double pole. As switching frequency changes, the characteristic doesn't change much.

At low frequency, instead of single pole, now it is a double pole. This double pole moves as switching frequency changes. Since the switching frequency range is not so wide, with in region 2, this double pole doesn't move too much.

There is a sign of a right half plane zero exists in this region though. From the graph, it can be seen that at 30k to 40kHz frequency range, the magnitude of the characteristic changes slope from -40dB/Dec to -20dB/Dec while the phase is continue reducing. For front-end application, the bandwidth is normally designed at 2 to 5kHz. This right half plane zero shouldn't impact too much on the feedback loop design.

Region 3 is ZCS region, which is not a desired operating region for this application.

From the simulation results, following observation could be made:

1. There is no beat frequency dynamic problem at the boundary between region 1 and region 2. This gives us opportunity to operate the converter right at

the resonant frequency of  $C_r$  and  $L_r$ , which is boundary point between region 1 and region 2.

2. In region 1, the converter behaves very similar to SRC. Beat frequency double pole and low frequency pole could be observed.

3. In region 2, the small signal characteristic of the converter is pretty stable with switching frequency change.

4. Between region 2 and region 3, beat frequency dynamic could be observed. The phase of small signal characteristic will jump for 180 degree across the boundary.

Above analysis is performed at given load. Next the impact of load change on the small signal characteristic will be investigated.

### **6.3.2 Impact of load variation on small signal characteristic**

In this part, the impact of load variation on the small signal characteristic of LLC resonant converter will be investigated. The simulations were performed in region 1 and region 2.

The small signal characteristic of LLC resonant converter with different load in region 1 ( $f_s=300\text{kHz} > f_r=250\text{kHz}$ ) is shown in Figure 6.21.

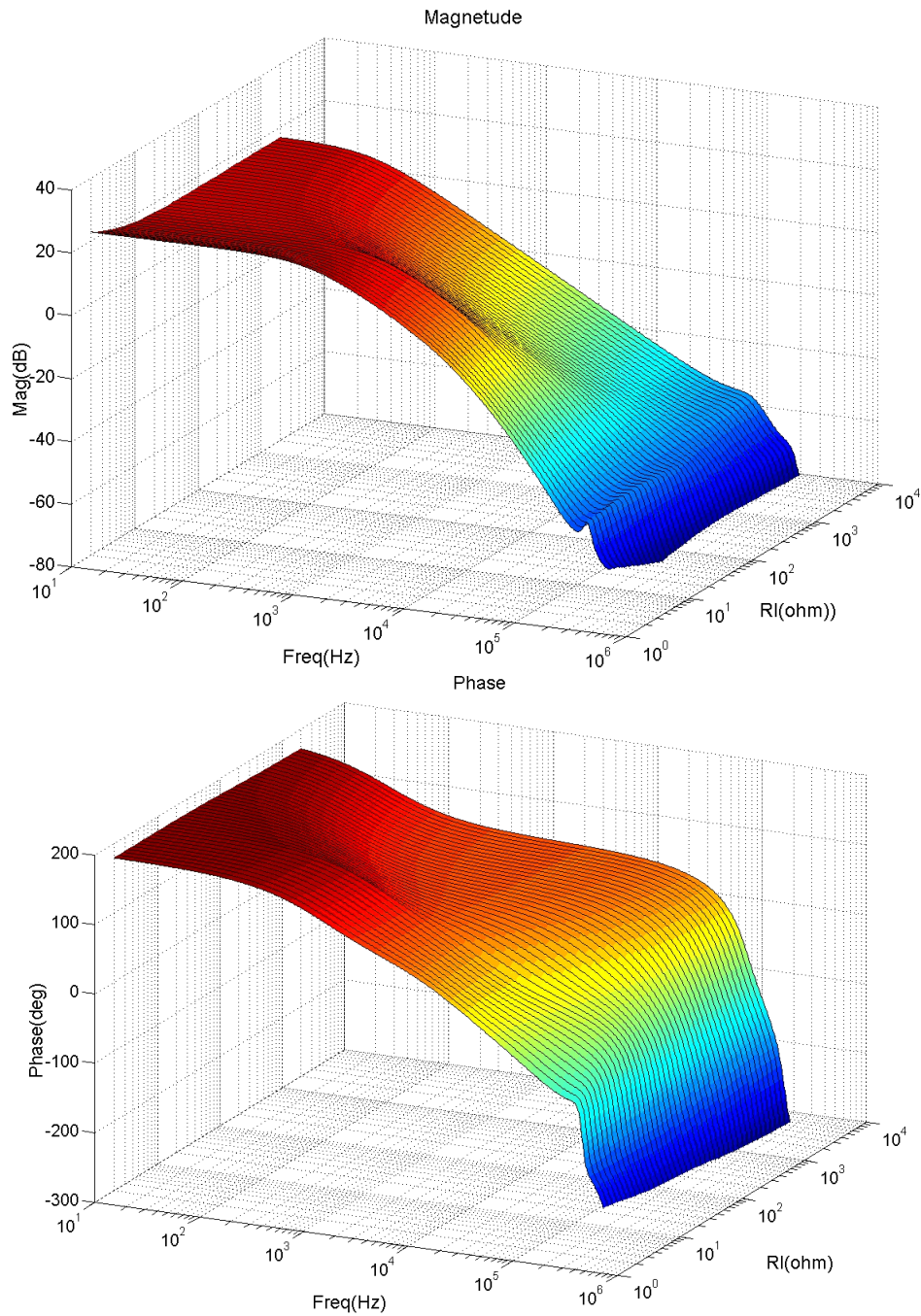

Figure 6.21 Bode plot of control to output transfer function of LLC resonant converter with load variation in region 1 ( $f_r=250\text{kHz}$ ,  $f_s=300\text{kHz}$ )



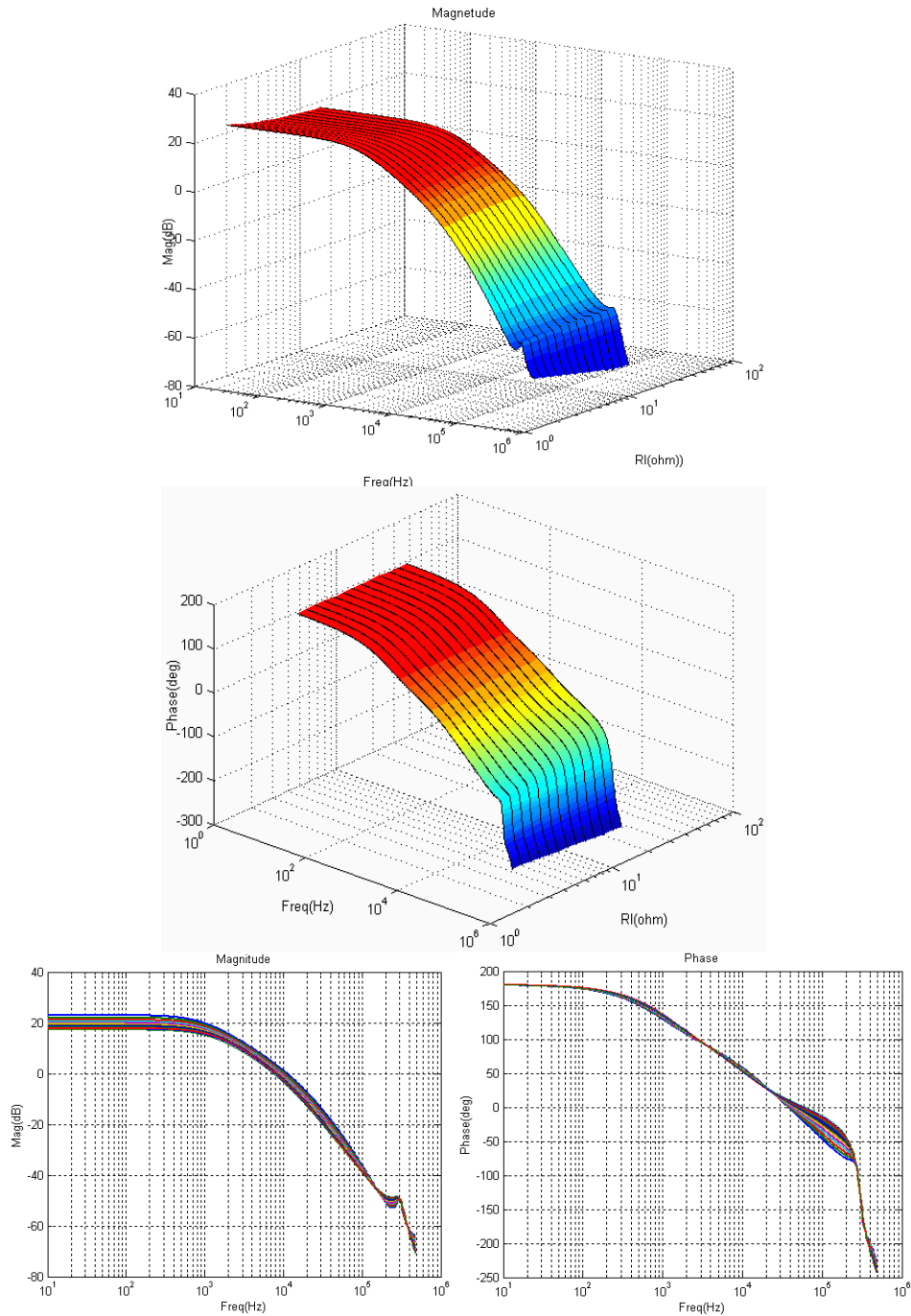

Figure 6.22 Bode plot of control to output transfer function of LLC resonant converter with load variation in region 1 ( $f_r=250\text{kHz}$ ,  $f_s=300\text{kHz}$ ) (full load to 25% load)

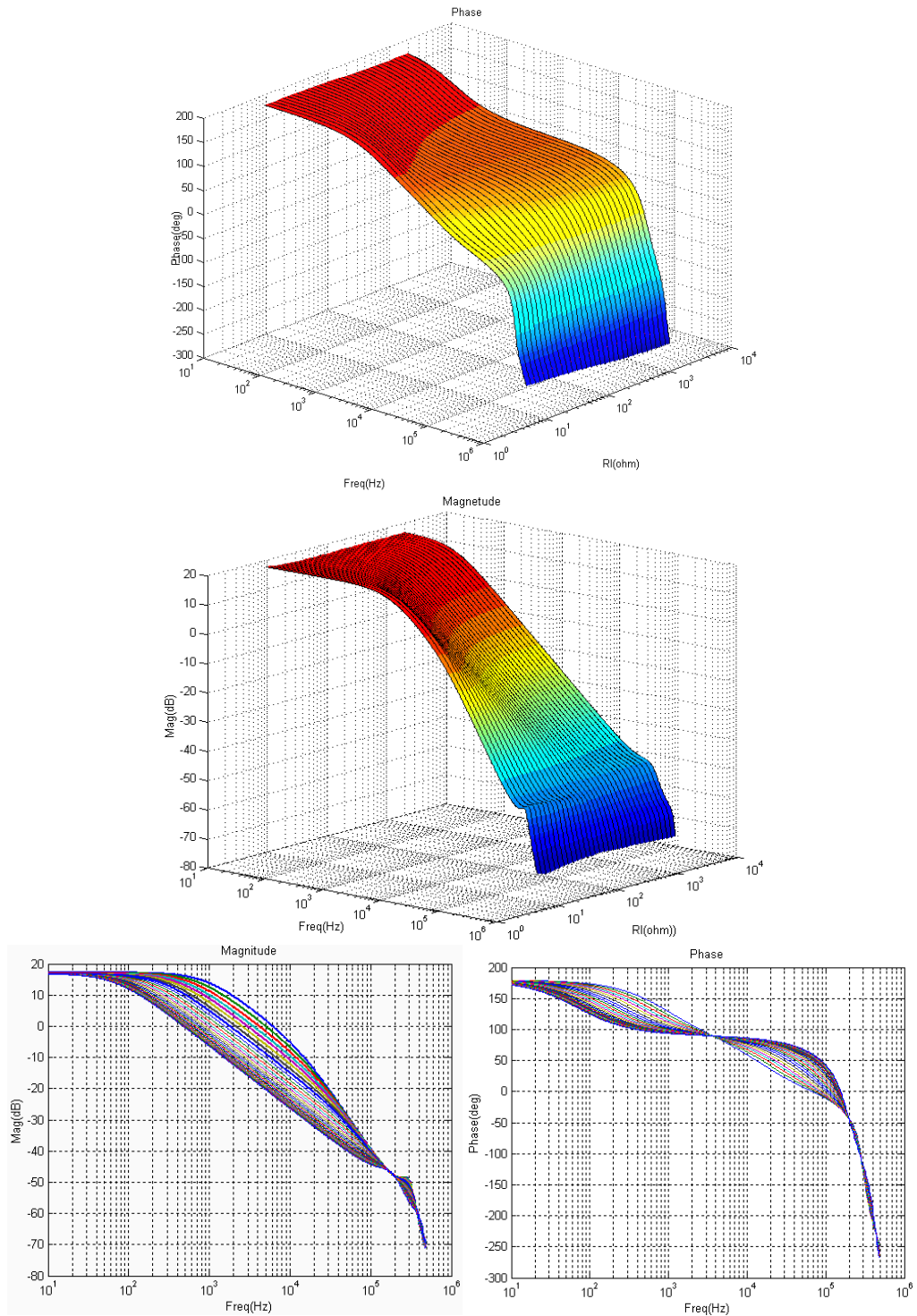

Figure 6.23 Bode plot of control to output transfer function of LLC resonant converter with load variation in region 1 (fr=250kHz, fs=300kHz) (25% to no load)

From the graph, several things could be observed. With load changes, the small signal characteristic of LLC resonant converter could be divided into two regions as shown in Figure 6.22 and Figure 6.23. In the first region, the characteristic doesn't change much. Within the region, the converter still works in continuous conduction mode. When load reduced to some level, the converter will run into DCM as discussed in Appendix B. Then the low frequency pole will move to lower frequency and beat frequency double pole will move to higher frequency. At light load, LLC resonant converter could be treated as a first order system in very wide frequency range.

The small signal characteristic of LLC resonant converter with different load in region 2 is shown in Figure 6.24. It could be divided into three load ranges according to different trends in the moving direction of poles and zeros as shown in Figure 6.25, Figure 6.26 and Figure 6.27.

In first load range, as load decreases, the Q of low frequency double pole will reduce. The right half plane zero tends to move to higher frequency and eventually move out of half switching frequency range.

In the second load range, however, the quality factor of low frequency double pole will increase as load further decrease.

As load continue reduce, the characteristic will come into load range 3. In load range 3, the low frequency double pole will split. One move to low

frequency and one move to high frequency, just as could be observed in PWM converter.

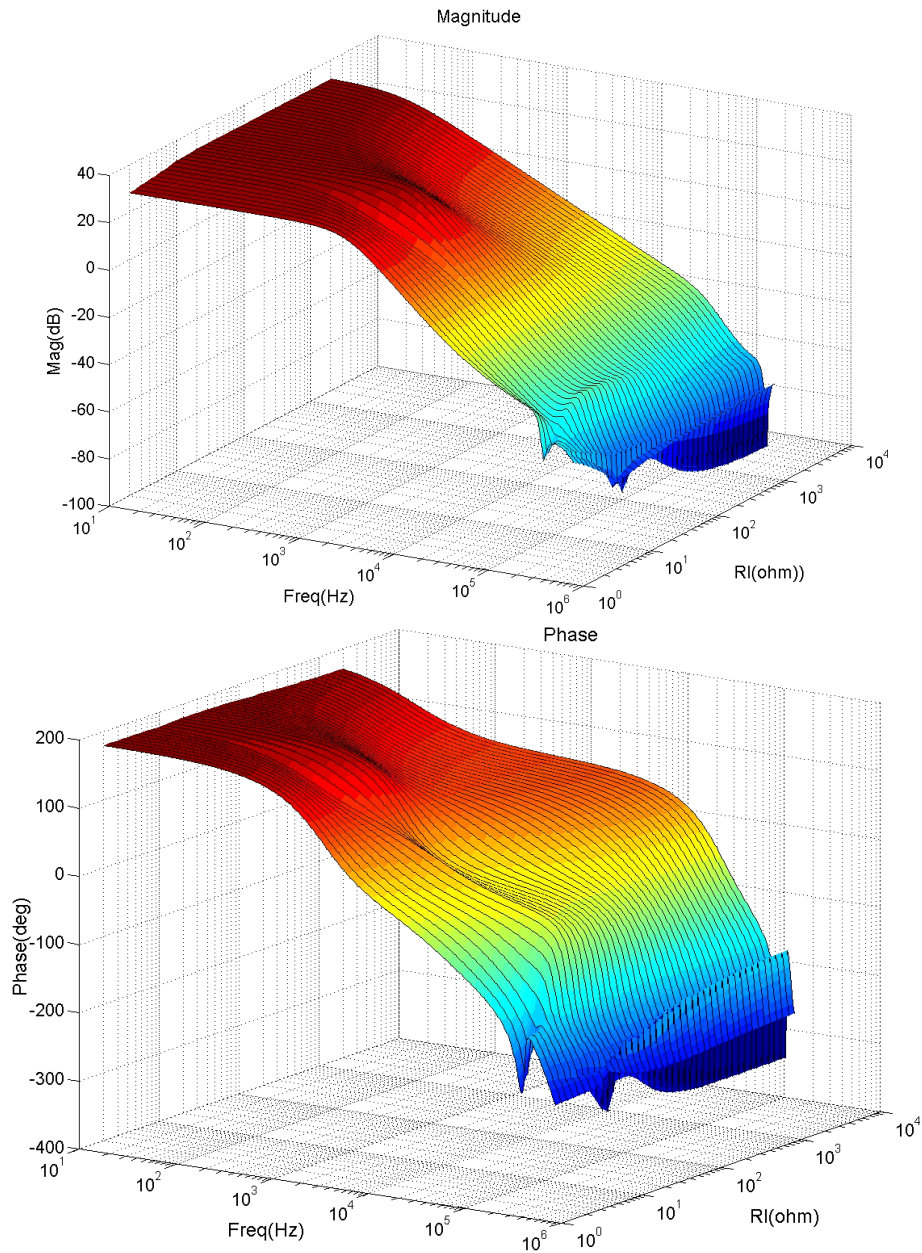

Figure 6.24 Bode plot of control to output transfer function of LLC resonant converter with load variation in region 2( $f_r=250\text{kHz}$ ,  $f_s=200\text{kHz}$ )

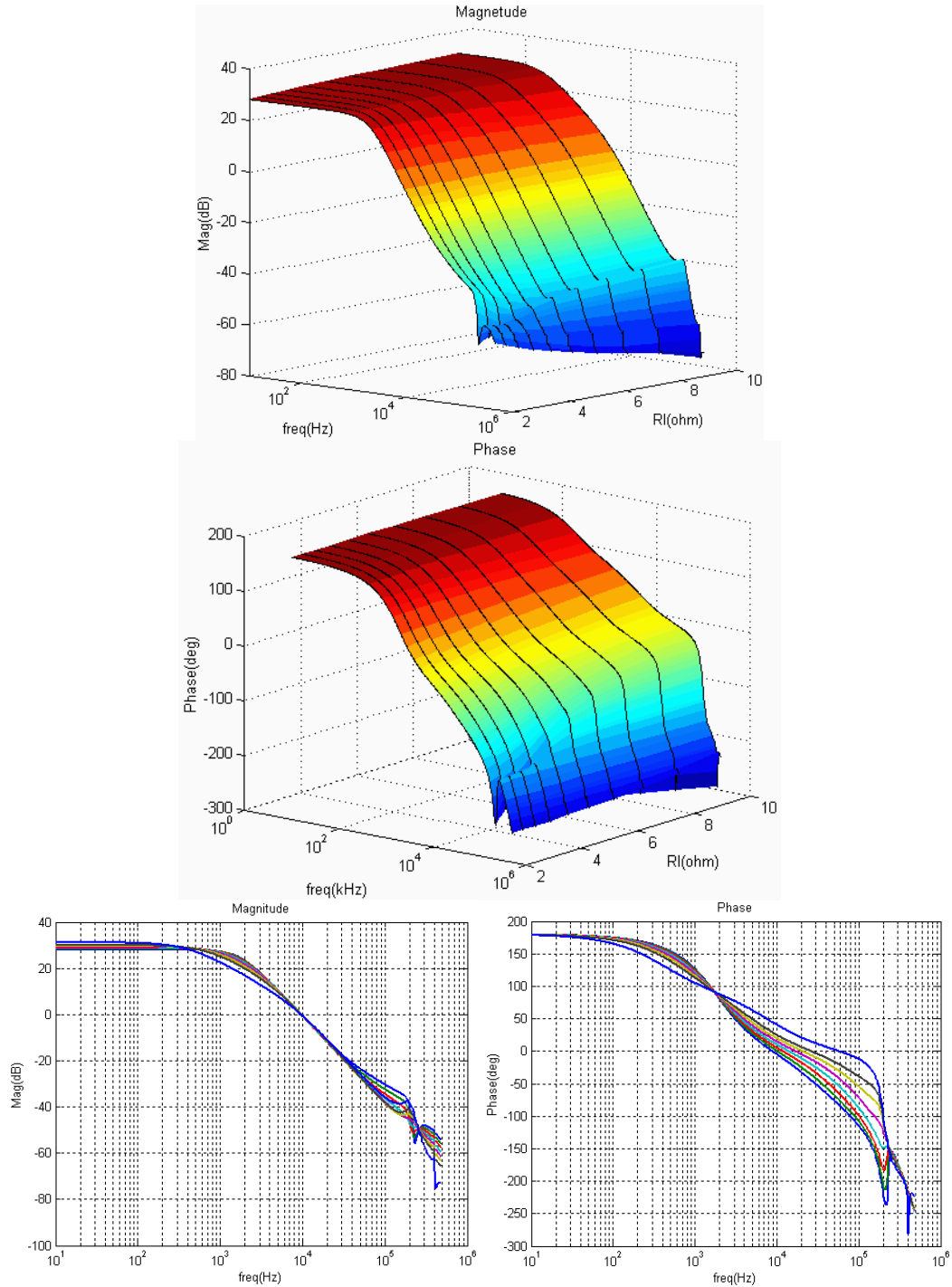

Figure 6.25 Bode plot of control to output transfer function of LLC resonant converter with load variation in region 2 ( $f_r=250\text{kHz}$ ,  $f_s=200\text{kHz}$ ) (full load to 25% load)

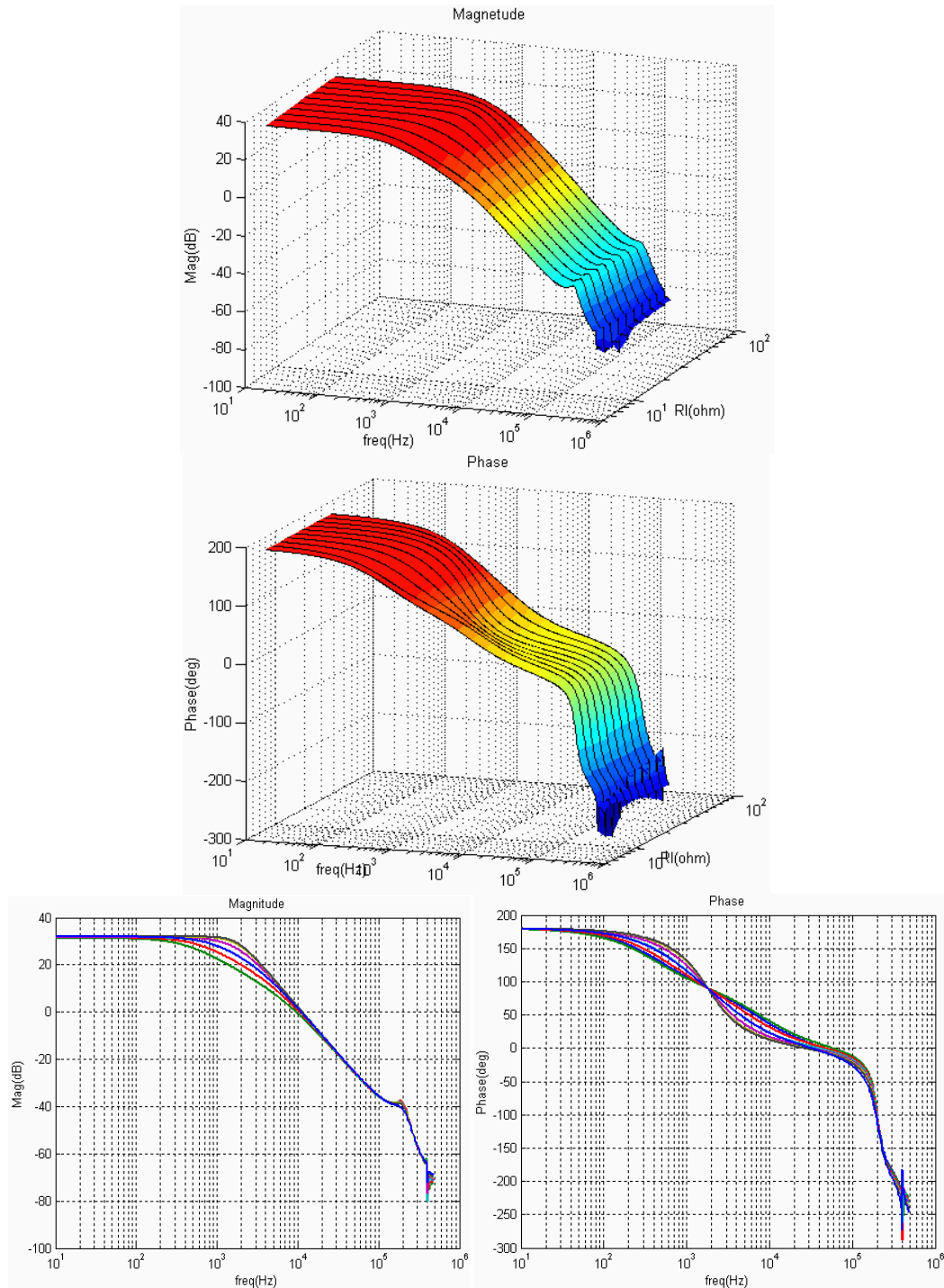

Figure 6.26 Bode plot of control to output transfer function of LLC resonant converter with load variation in region 2 ( $f_r=250\text{kHz}$ ,  $f_s=200\text{kHz}$ ) (25% to 10% load)

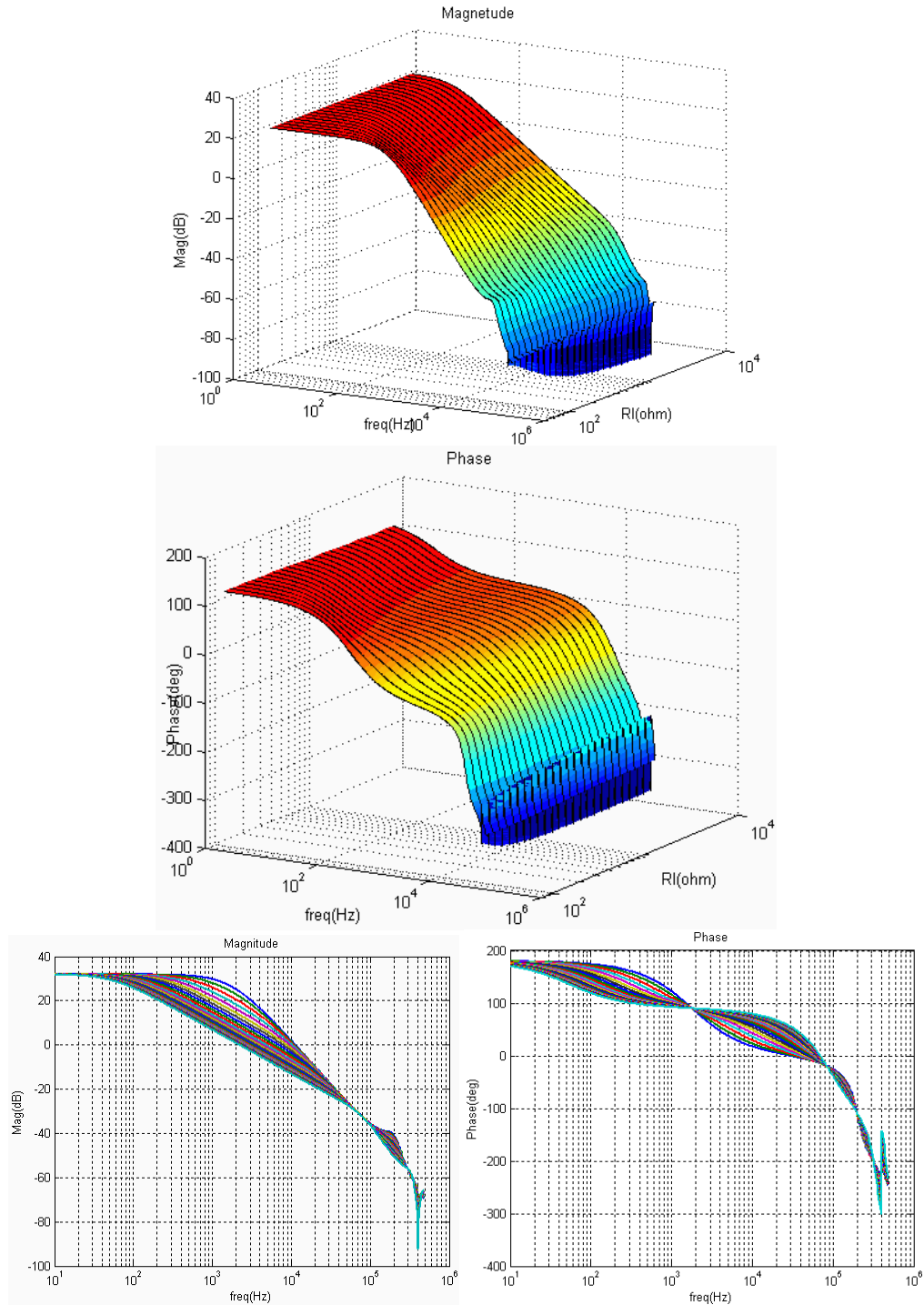

Figure 6.27 Bode plot of control to output transfer function of LLC resonant converter with load variation in region 2 ( $f_r=250\text{kHz}$ ,  $f_s=200\text{kHz}$ ) (10% to no load)

From above simulation results, one conclusion is that with light load, one low frequency pole will exist. This needs to be considered when design the compensator.

## 6.4 Impact of circuit parameters

In this part, the impact of some components value on the small signal characteristic of LLC resonant converter will be shown. The components will be investigated include: output filter capacitor, magnetizing inductance  $L_m$ , and resonant tank impedance.

### 6.4.1 Impact of output capacitance

In this part, the small signal characteristic of LLC resonant converter with different  $C_o$  will be simulated.

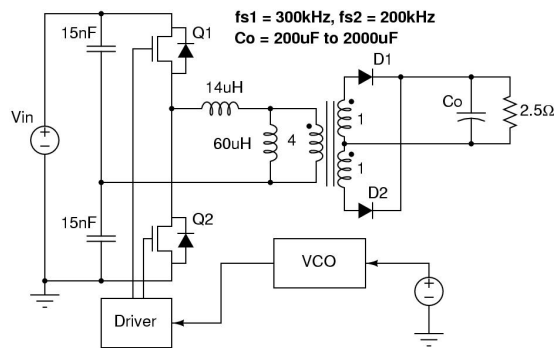

Figure 6.28 Simulation setup for output capacitor impact on small signal characteristic

The converter is shown in Figure 6.28, the resonant frequency is 250kHz. The simulation will be performed in two switching frequency. One frequency is in region 1 at 300kHz as shown in Figure 6.29. The other simulation is performed in region 2, with switching frequency at 200kHz as shown in Figure 6.30.



From both simulation,  $C_o$  only impact the low frequency pole and doesn't affect high frequency poles.

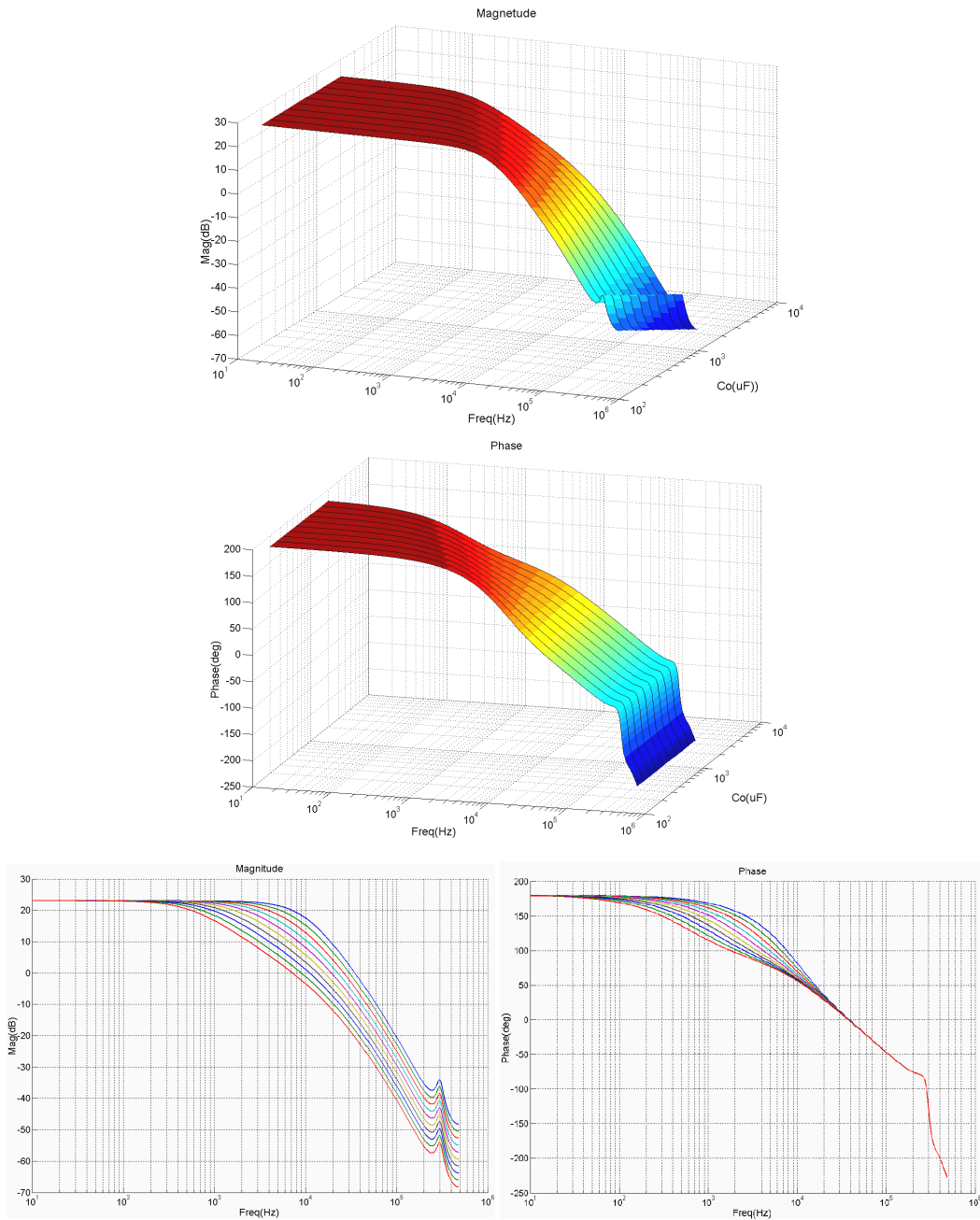

Figure 6.29 Bode plot of control to output transfer function with different output capacitance with switching frequency 300kHz(region 1)

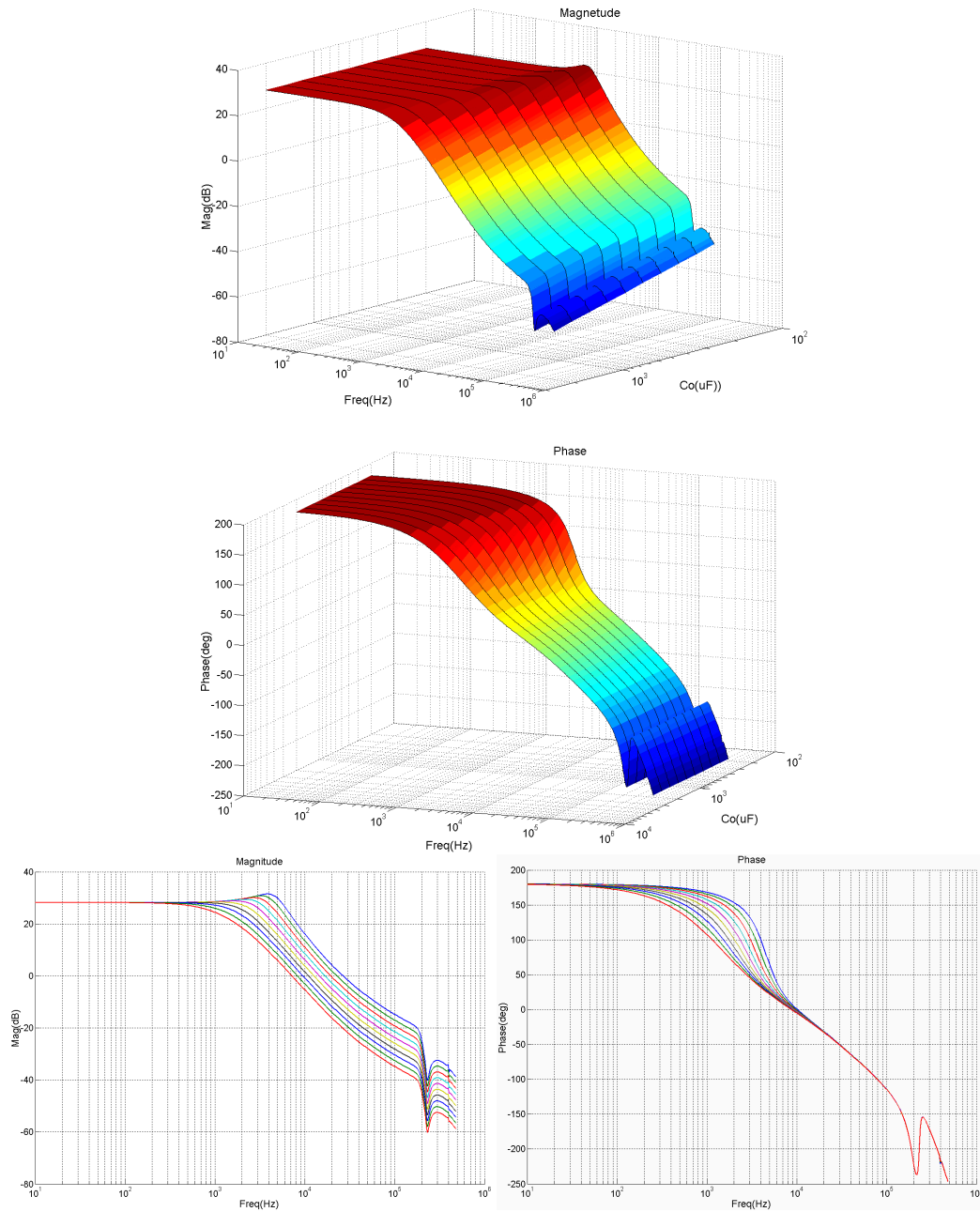

Figure 6.30 Bode plot of control to output transfer function with different output capacitance with switching frequency 200kHz(region 2)

## 6.4.2 Impact of magnetizing inductance

In this part, the small signal characteristic of LLC resonant converter with different  $L_m$  will be simulated.

The converter been simulated is shown in Figure 6.31, the resonant frequency is 250kHz. Same as for previous case, two switching frequency points will be choose. One frequency is in region 1 at 300kHz as shown in Figure 6.32. The other simulation is performed in region 2, with switching frequency at 200kHz as shown in Figure 6.33.

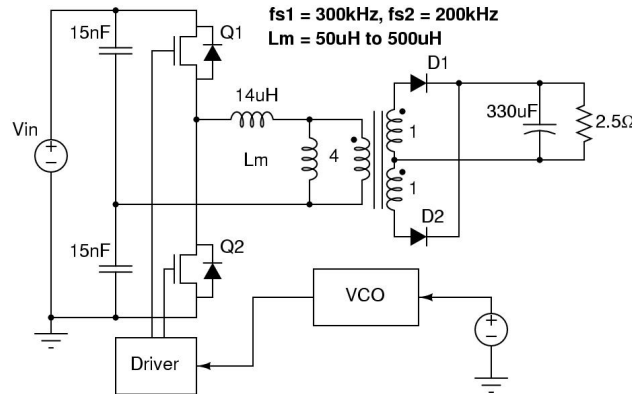

Figure 6.31 Simulation setup for magnetizing inductance impact on small signal characteristic

From the simulation in region 1,  $L_m$  doesn't affect the small signal characteristic in this region at all. With  $L_m$  changed by 10 times, the small signal characteristic is almost constant. In region 2,  $L_m$  has great impact on the DC gain of the small signal characteristic. With larger  $L_m$ , the right half plane zero also tends to shift to lower frequency.

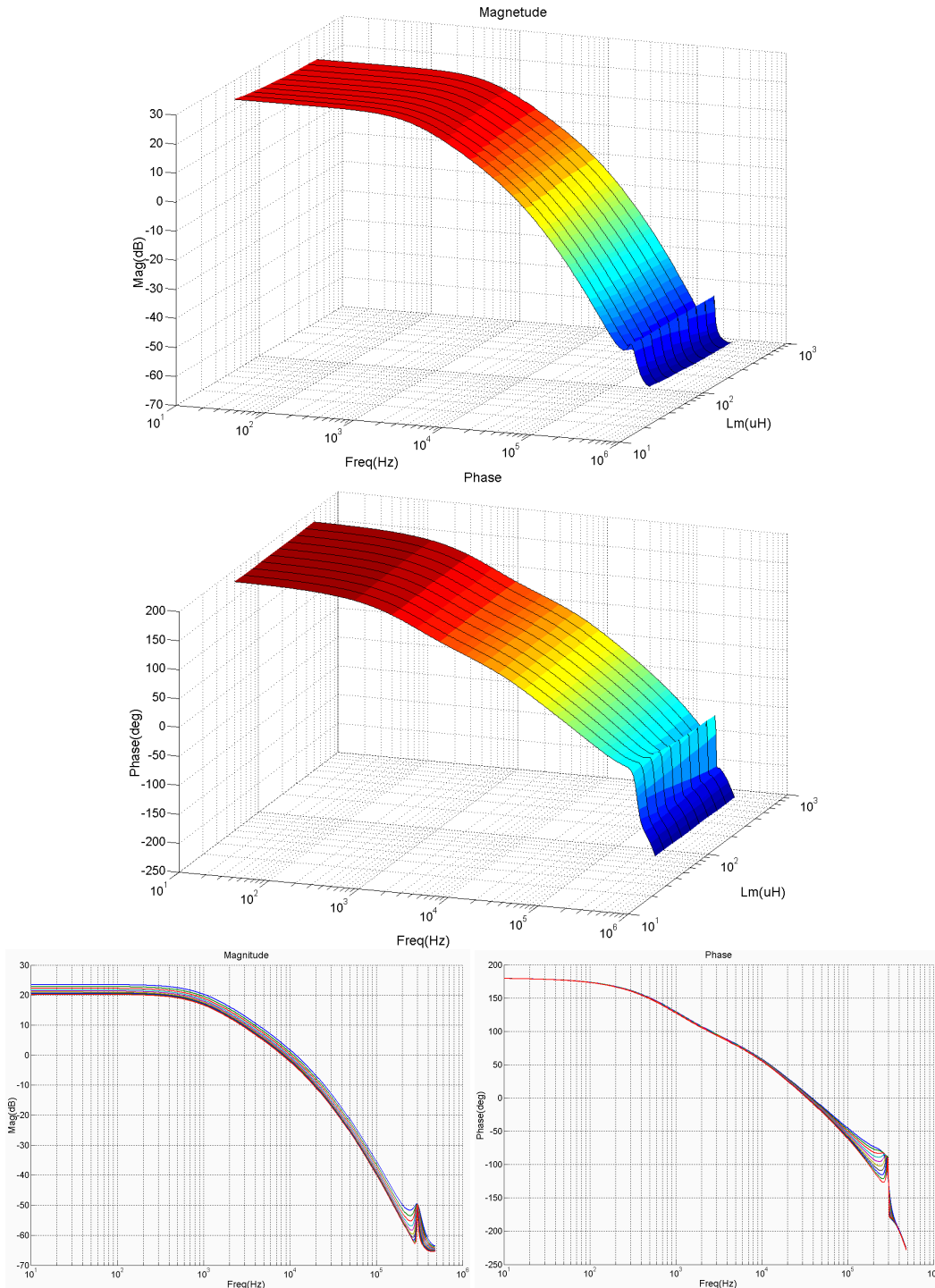

Figure 6.32 Bode plot of control to output transfer function with different magnetizing inductance with switching frequency 300kHz(region 1)

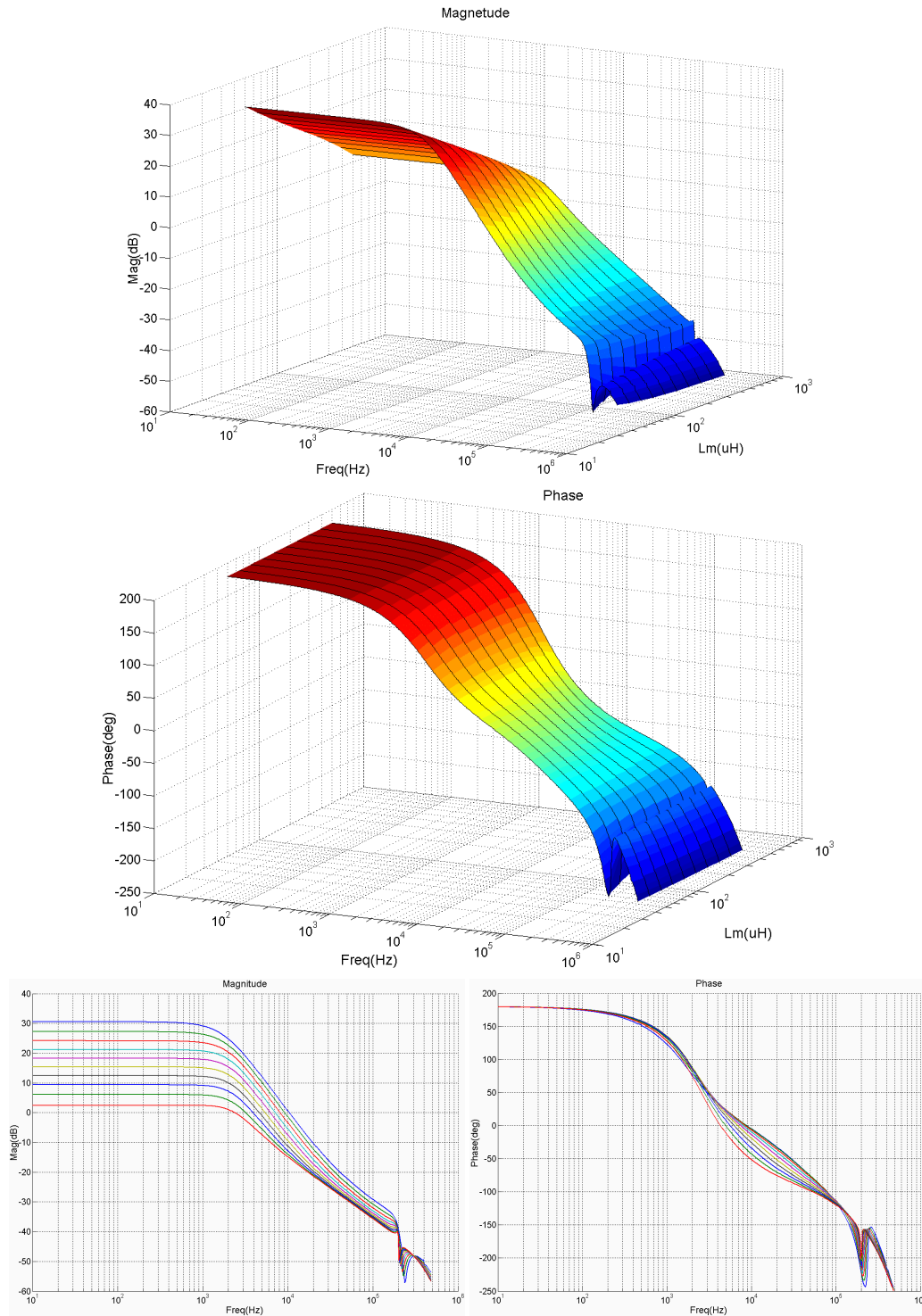

Figure 6.33 Bode plot of control to output transfer function with different magnetizing inductance with switching frequency 200kHz(region 2)

### 6.4.3 Impact of resonant tank impedance

In this part, the small signal characteristic of LLC resonant converter with different resonant tank impedance will be simulated. The resonant frequency is kept constant in the simulation. The converter been simulated is shown in Figure 6.34, the resonant frequency is kept constant at 250kHz, which means as  $L_r$  been changed,  $C_r$  will be changed accordingly. Same as for previous case, two switching frequency points will be choose. The 300kHz case is shown in Figure 6.35. The 200kHz case is shown in Figure 6.36.

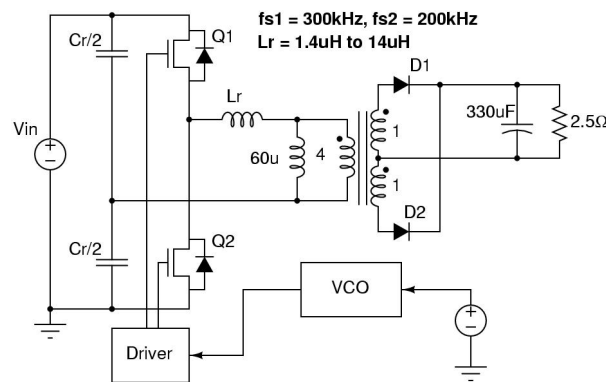

Figure 6.34 Simulation setup for resonant tank impedance impact on small signal characteristic

As from the simulation, in region 1, as impedance of resonant tank increases, which means increase  $L_r$  and reduce  $C_r$ , the DC gain will increase. This is understandable since with higher impedance, the  $Q$  with given load will increase, then the slope of the DC characteristic will have larger value, which is the DC gain in small signal characteristic. Another interesting thing is that the first pole will move with different resonant tank impedance, which means in LLC resonant converter, the lowest pole is not determined by output filter only. In region 2, the

similar impact on DC gain could be observed. With larger  $L_r$ , one low frequency pole also moves to higher frequency.

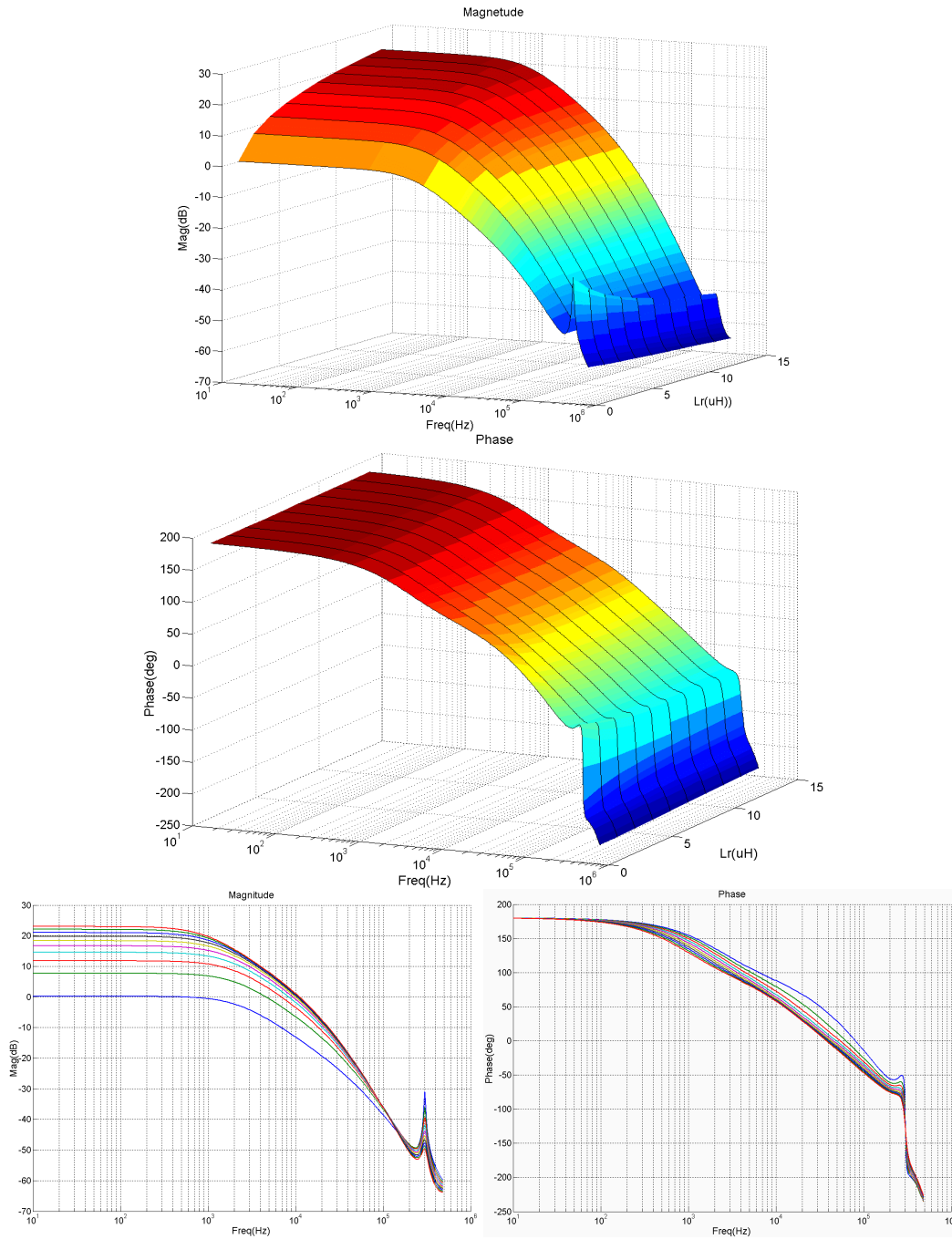

Figure 6.35 Bode plot of control to output transfer function with different resonant inductance with switching frequency 300kHz(region 1)

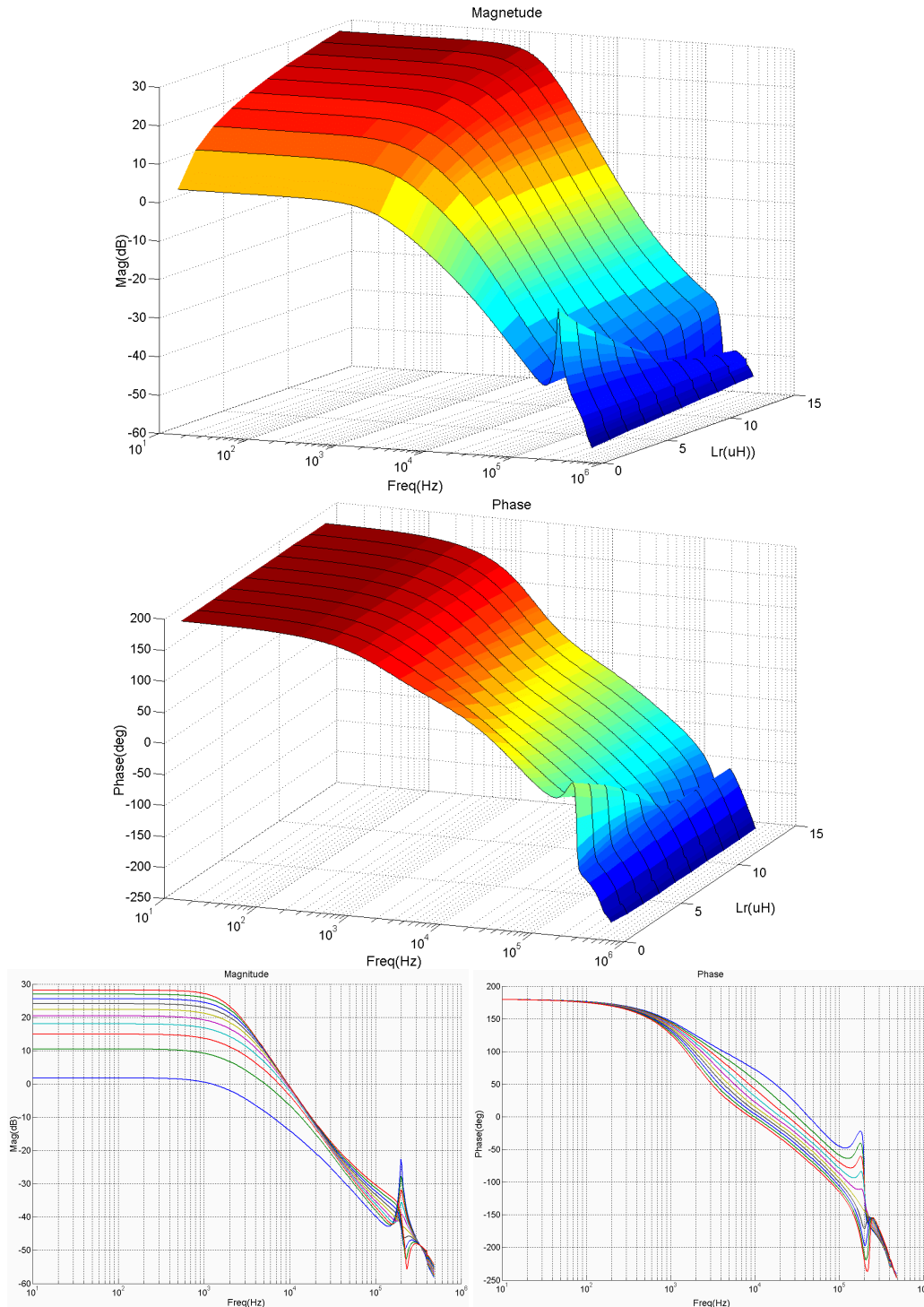

Figure 6.36 Bode plot of control to output transfer function with different resonant inductance with switching frequency 200kHz(region 2)



## 6.5 Test verification

In this part, a test circuit was built with same parameters as used in the analysis. The test setup is shown in Figure 6.37.

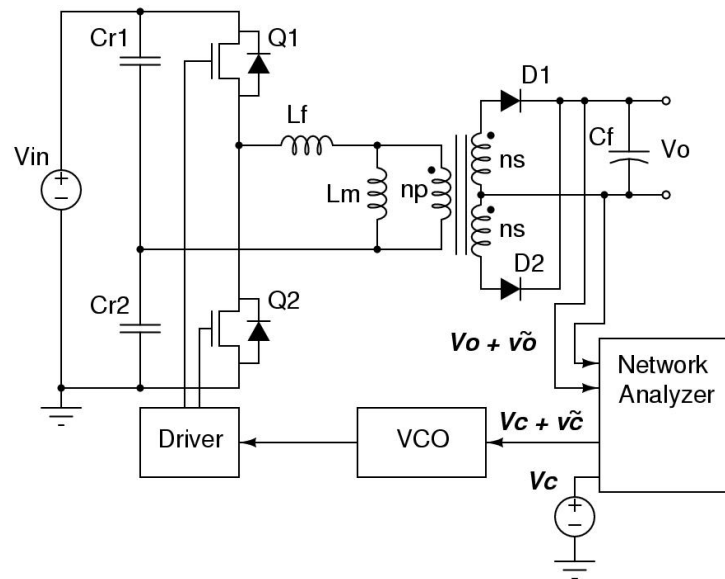

Figure 6.37 Test setup up for small signal characterization of LLC converter

In Figure 6.38, the results in region 1 with full load are shown for three methods: test, simulation and extended describing function. From the comparison, these three results match each other very good.

In Figure 6.39, the results in region 2 with full load are shown for three methods: test, simulation and extended describing function. From the comparison, these three results match each other very good.

From the verifications, both methods match test results very well. These two methods have their pros and cons. For simulation method, it is easy to implement. With powerful computer and software, it is also fast. The problem is lacking of

insight of the model of the converter. It just gives the bode plot of the characteristic of the converter. If more information is needed, extended describing function method could be helpful. With extended describing function method, more information about the small signal characteristic of the converter could be derived. The drawback is that to build the model, a thorough understanding of the converter is critical. When the operating modes of the converter are too complex, this will be a painful process.

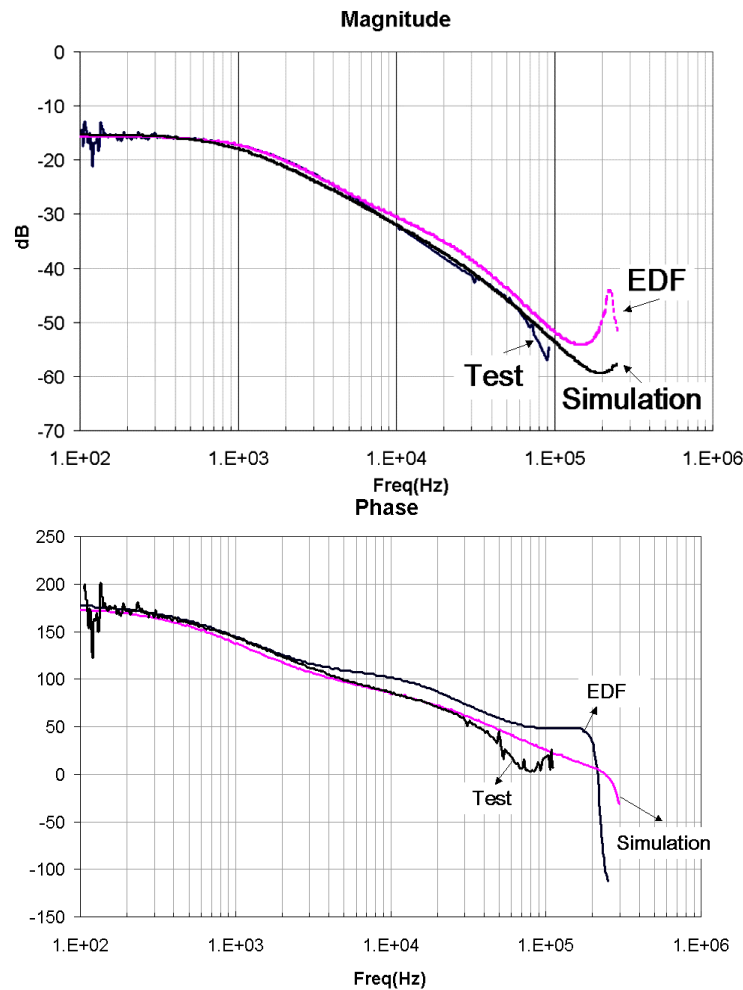

Figure 6.38 Bode plot of control to output transfer function at full load in region 1

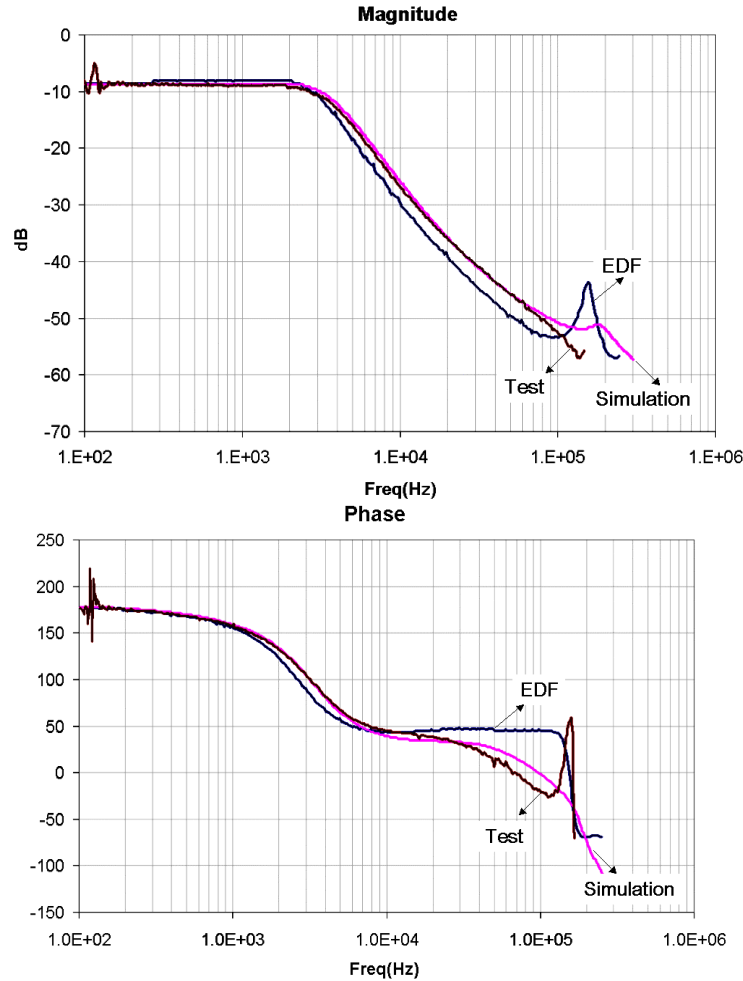

Figure 6.39 Bode plot of control to output transfer function at full load in region 2

## 6.6 Compensator design for LLC resonant converter

From above analysis, we have a complete picture of the small signal model of LLC resonant converter. Base on this information, the compensator could be designed.

First, as seen in the characteristic of LLC resonant converter, the phase at DC is 180-degree instead of 0-degree as seen for PWM converter. This means from the control voltage point of view, LLC resonant converter is an inverter. As

control voltage increases, output voltage will decrease. This is because of the fact that for resonant converter to work under ZVS condition, the output voltage will decrease when switching frequency increases. For voltage-controlled oscillator, when its input voltage increases, the frequency will increase. For PWM converter, duty cycle will increase as control voltage increases, which will increase the output voltage. For PWM converter, the compensator is a negative feedback as shown in Figure 6.40. For LLC resonant converter, a positive input compensator is needed as shown in Figure 6.41 because of the negative transfer function of the converter.

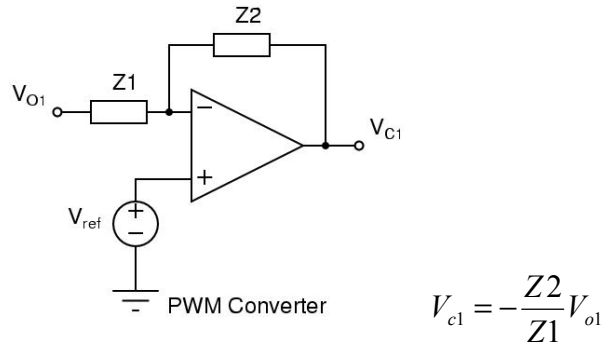

Figure 6.40 Compensator for PWM converter

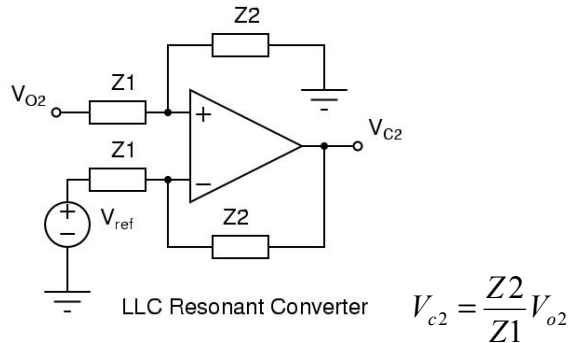

Figure 6.41 Compensator structures for LLC resonant converter

For LLC resonant converter, its designed operating region is region 2 (switching frequency lower than series resonant frequency). In this region, the small signal characteristic of LLC resonant converter is pretty stable with changing of switching frequency. Although a RHZ exists in this region, it never moves to very low frequency. The more significant impact is the load change. With light load, one pole will move to very low frequency. With integrator in the compensator, this might introduce conditional stable situation.

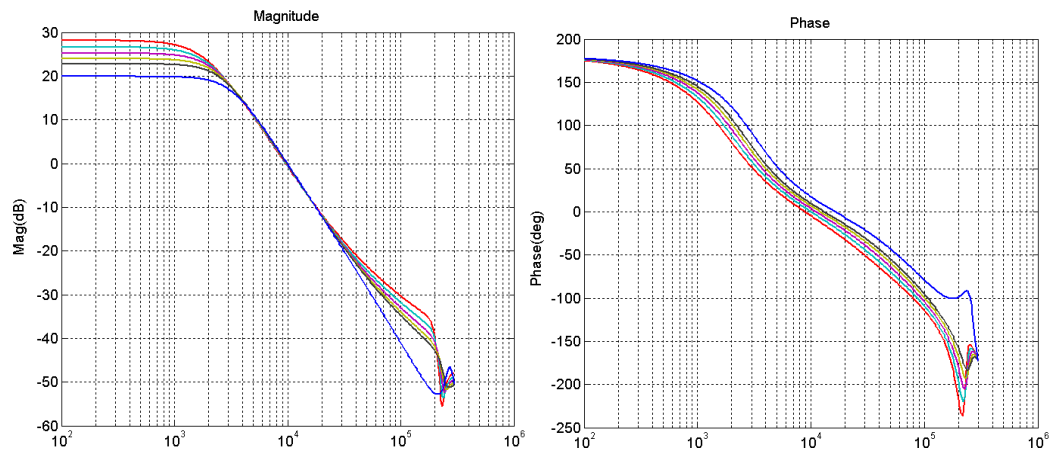

Figure 6.42 Small signal characteristic of LLC converter in region 2

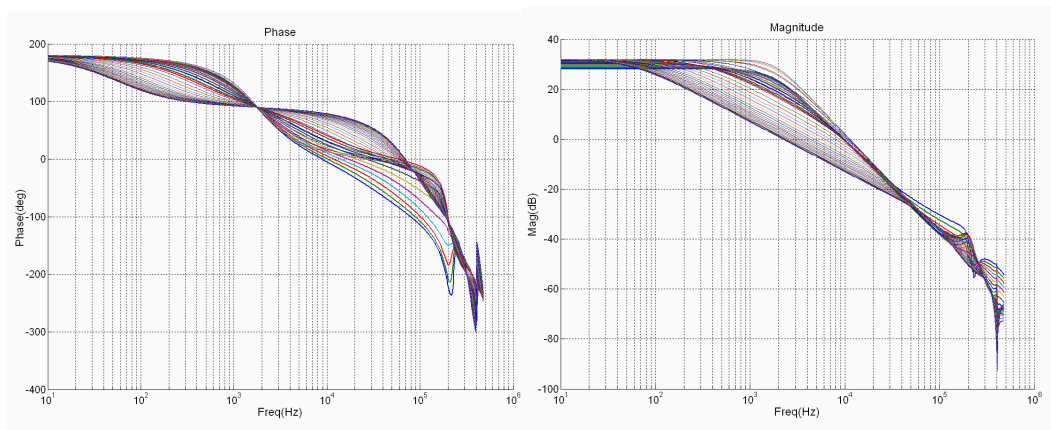

Figure 6.43 Load impact on small signal characteristic of LLC converter in region 2

Although region 2 is the designed operating region, converter might operate in region 1 due to the fact that the intermediate bus is loosely regulated. Load or AC line transient could cause this voltage rise to as high as 430V. During those conditions, the converter will operate in region 1. So the characteristic in region 1 also needs to be considered during compensator design. In region 1, the converter will have a beat frequency double pole and one low frequency pole.

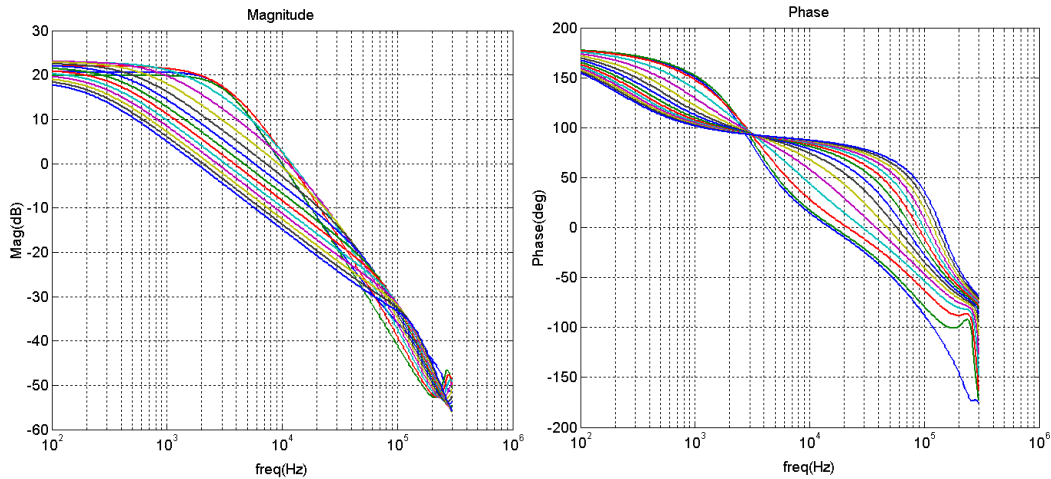

Figure 6.44 Small signal characteristic of LLC converter in region 1

As load changes in region 1, similar phenomenon could be observed as in region 2. The double pole will split and one moves to high frequency, one moves to very low frequency.

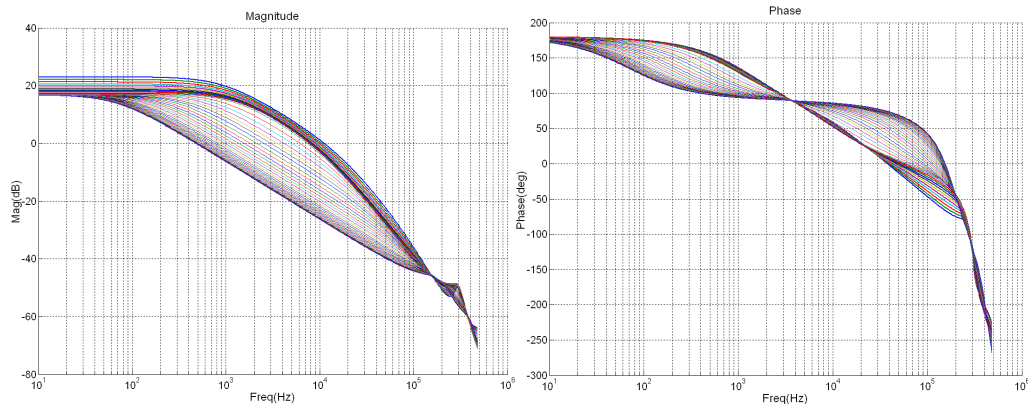

Figure 6.45 Load impact on small signal characteristic of LLC converter in region 1

With above information, the compensator could be designed. Since the RHZ is at pretty high frequency, it will not impact the compensator design so much. What need to be dealt with are one double pole and one ESR zero. At light load condition, as one pole will move to low frequency, the low frequency pole need to be considered. To compensate this system, a compensator with one integrator, 2 poles and 2 zeros is used. The two zeros are placed to compensate the double pole exists in the system. Another consideration is the low frequency pole due to light load. With these two considerations, one zero is placed at low frequency to prevent conditional stable from happening. Another zero is placed around the double pole. The poles are placed to compensate the ESR zero and provide more attenuation at switching frequency. The compensator is shown in Figure 6.46. With this compensator, the loop gain in different operating regions is shown in Figure 6.47 and Figure 6.48. The test results of LLC resonant converter under load change are shown in Figure 6.49 and Figure 6.50. The output voltage is within 5% regulation window during full range load step.

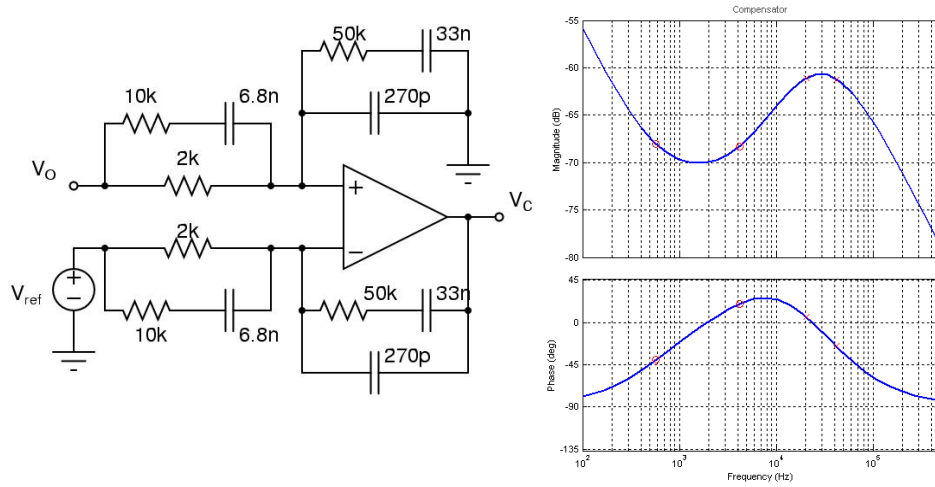

Figure 6.46 Compensator designed for LLC resonant converter

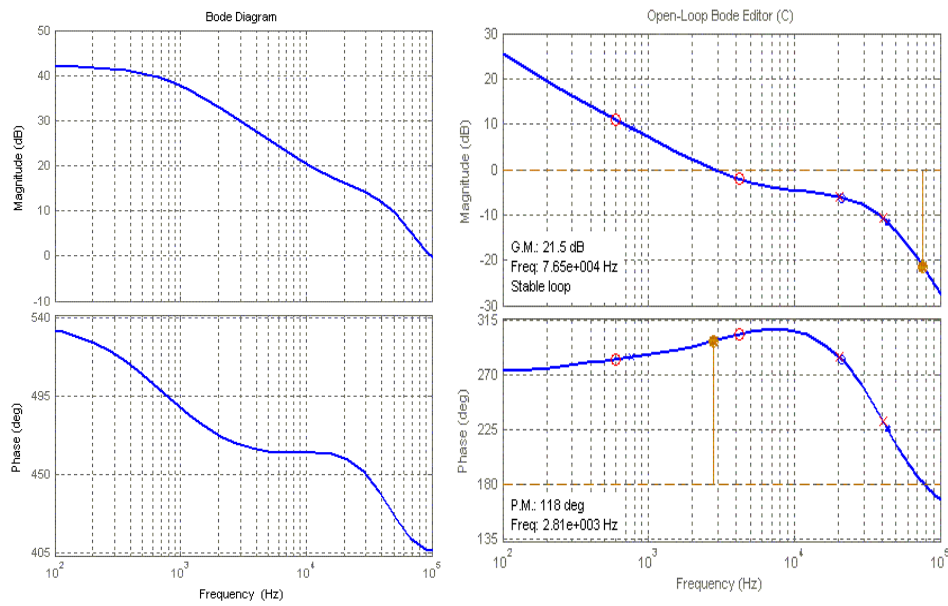

Figure 6.47 Plant bode plot and loop gain bode plot in region 1



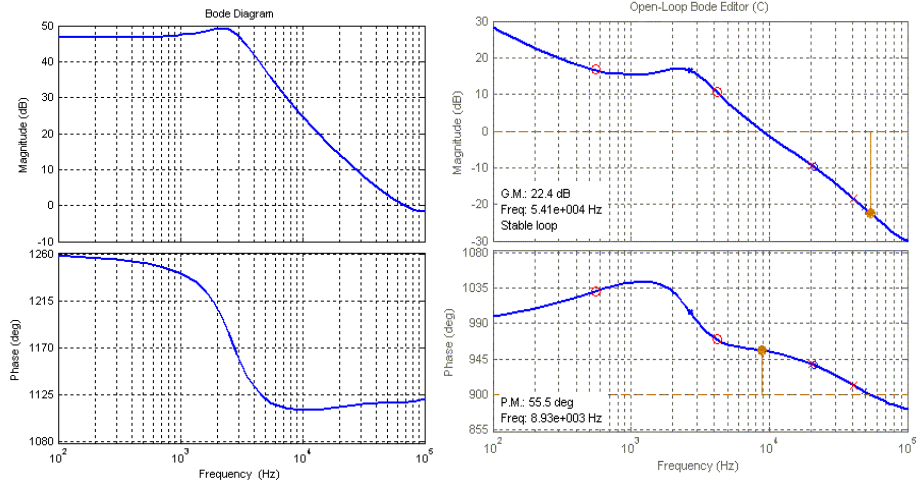

Figure 6.48 Plant bode plot and loop gain bode plot in region 2

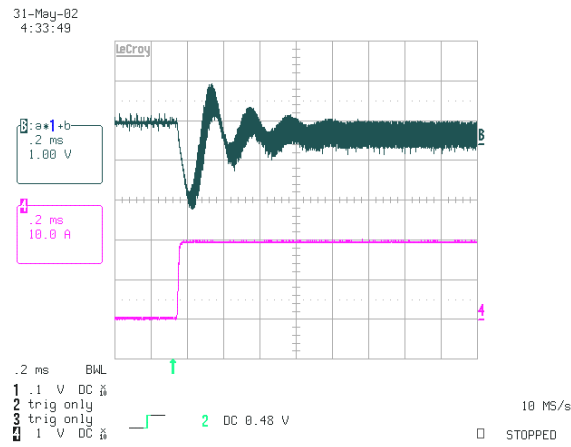

Figure 6.49 Test result of load change from no load to full load

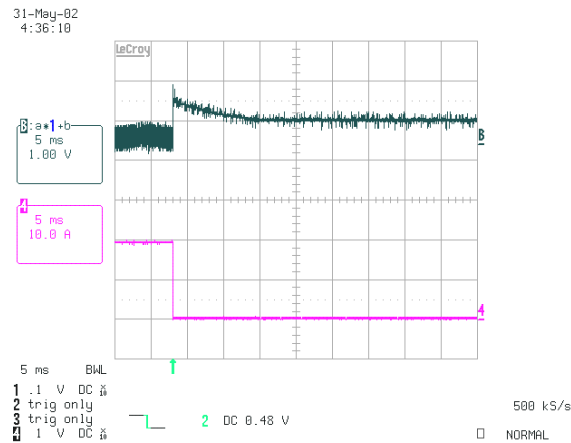

Figure 6.50 Test result of load change from full load to no load

## **6.7 Summary**

In this chapter, small signal characteristic of LLC resonant converter is been investigated. Two methods were used to perform the analysis: simulation and extended describing function method. With simulation, the small signal characteristic of the converter could be covered with any operation mode. The drawback is lack of insight of the characteristic. With extended describing function method, more information could be obtained. The drawback is the needs of develop the model file, which is not an easy task to cover all operating points. The best way is to combine the power of these two methods. Then a more accurate, more efficient and more comprehensive characteristic of any converter could be obtained.

The results of these two methods match very well. They were also been verified with test setup.

Base on this information, the compensator could be designed and the front end DC/DC converter is a complete system now.